

## CHAPTER 4. SUBDIVISION STANDARDS

### Article 4.A. Subdivision Design

#### Sec. 4-A-1 Purpose

---

These regulations are designed to be administered in a manner to:

- A. Establish adequate and accurate records of land subdivision;
- B. Harmoniously relate the development of the various tracts of land to the existing community and facilitate the future development of appropriate adjoining tracts;
- C. Provide for adequate, safe, and efficient public utilities and improvements to provide for public parks, schools, and other public purposes (including, but not limited to, libraries, fire stations, and other similar public facilities);
- D. Provide for light, air, and space for the public;
- E. Provide for protection from fire, flood, landslide, and other disasters;
- F. Provide for efficient design of utilities, stormwater drainage facilities, streets, and sidewalks;
- G. Ensure that the cost of improvements that primarily benefit the parcel proposed for development be borne by the owners/developers of the parcel, and the costs of improvements that primarily benefit the whole community be borne by the whole community;
- H. Provide for the administration and regulation of resource protection areas and open spaces;
- I. Protect groundwater and surface water from contamination by stormwater runoff and other pollution sources;
- J. Reduce potential on-street congestion impacts of new development by providing alternative travel routes, meaningful choice of alternative transportation modes, shortened journey-to-work trips, and fewer overall vehicle miles traveled; and
- K. Inform each subdivider of the standards and criteria by which development proposals will be evaluated, and provide information as to the type and extent of improvements required.

#### Sec. 4-A-2 Applicability

---

- A. **Generally.** This Article applies to all development which involves the installation of streets, sidewalks, trails, and/or utilities, except as specifically provided herein pursuant to the authority found within Colorado Revised Statutes (C.R.S.) §31-23-214, *Subdivision Regulations*.
- B. **Policy and Design Objectives for Streets, Sidewalks, and Trails.** *Sec. 4-A-5, Streets, Sidewalks, and Trails*, sets out the policy and design objectives for streets, sidewalks, and trails, in accordance with the 2019 Imagine Winter Park Town Plan (the "Comprehensive Plan") and the 2014 Community Trails Plan (the "Community Trails Plan"). Specific engineering and dimensional standards are provided in the Town of Winter Park Standards and Specifications for Design and Construction (the "Standards").
- C. **Policy and Design Objectives for Utilities.** *Sec. 4-A-10, Utilities*, sets out the policy and design objectives for public utilities in accordance with the Comprehensive Plan. Specific engineering standards are provided in the Standards.
- D. **Policy and Design Objectives for Stormwater Drainage.** *Sec. 4-A-11, Stormwater Drainage*, sets out the policy and design objectives for the installation of stormwater drainage systems. In addition to the standards within, the drainage systems are regulated by standards promulgated in the Standards.
- E. **Compatibility.** All development and proposed uses under this Article shall be compatible with the natural environment in the Town and any and all standards for the Town, including the Standards.

#### Sec. 4-A-3 Subdivision Classifications

---

- A. **Generally.** The subdivision classification system provides for different procedures depending upon the scale and impacts of the proposed subdivision. There are two (2) types of subdivisions for the purposes of this UDC:
  - 1. Minor subdivisions; and
  - 2. Major subdivisions.
- B. **Applicability.** The procedures of this Section shall apply to all subdivisions or re-subdivisions that result in the portioning, dividing, combining or altering of any lot, parcel or tract of land, including land used for condominiums, apartments or any other multiple dwelling units or creation of an estate in airspace, except any subdivisions that are specifically excluded by state law.
- C. **Subdivision Requirement.** No building, utility connection, electrical connection, or similar permit shall be issued, for any development or land division that is required to be processed as set out in this Section until a plat has been approved and submitted to the Town for recording with the Grand County Clerk and Recorder.
- D. **Minor Subdivision.**
  - 1. *Generally.* A minor subdivision is a subdivision containing four (4) or fewer lots or dwelling units.
  - 2. *Requirements.* Minor subdivisions shall require final plat filing, processing, and approval in accordance with [Sec. 7-E-6, Final Plat](#) however, the review criteria for a preliminary plat shall apply to review of minor subdivision plats in addition to the review criteria for a final plat.
- E. **Major Subdivision.**
  - 1. *Generally.* A major subdivision is a subdivision containing five (5) or more lots or dwelling units.
  - 2. *Requirements.* Major subdivisions shall require sketch plan, preliminary plat, and final plat filing, processing, and approval in accordance with [Sec. 7-E-4, Sketch Plan](#), [Sec. 7-E-5, Preliminary Plat](#), and [Sec. 7-E-6, Final Plat](#).
- F. **Subdivision Exemption.** Refer to [Sec. 7-E-2, Subdivision Platting: Requirements and Exemptions](#)

#### **Sec. 4-A-4 Subdivision Design Principles**

---

- A. **Generally.** The design principles of this Section are intended to result in plans and plats for development or redevelopment that reflect high-quality design, but not to require a reduction of development potential to less than is allowed by this UDC. The principal objective of this Section is to ensure that roads, lots, landscaping, common open space, and other elements of a proposed development are appropriately configured.
- B. **Application of Design Principles.** These principles are to be applied to new development or redevelopment to the extent that they shall not:
  - 1. Directly conflict with the other requirements of this UDC; and
  - 2. Result in conditions that further reduce the density or intensity of development that is permitted on the parcel proposed for development by compliance with the other standards of this UDC.
- C. **General Design Objectives.** Development in all zones shall result in harmonious, interrelated combinations of compatible buildings and uses that utilize:
  - 1. *Buffers.* Provide appropriate space for buffers and transitions between:
    - a. Incompatible land uses (see [Article 6.C, Landscaping, Buffering, and Screening](#)); and
    - b. Obvious changes in density or intensity between lots alongside and rear lot lines.
  - 2. *Connectivity.* Provide vehicular and pedestrian linkages between residential uses and recreational, institutional, retail, service, and office uses, with anticipated and planned future linkages to new development;
  - 3. *Access.* Organize the development such that it minimizes interference with existing access to adjacent and nearby properties, unless new and improved access is provided by the proposed development;
  - 4. *Environment.* Minimize impacts to water quality from runoff, erosion, or pollutant discharge; and
  - 5. *Development Pattern.* If there is a discernible development pattern in the immediate area of the development:

- a. Reinforce that pattern, particularly at the edges where the proposed development is separated from existing development by a local street;
- b. Implement a redevelopment plan for the area which anticipates a different pattern; or
- c. Create a strategically located landmark which gives a unique and positive identity to the area in which it is located.

#### Sec. 4-A-5 Streets, Driveways, Sidewalks and Trails

---

- A. **Generally.** Streets, driveways, sidewalks, and trails shall be designed and constructed in compliance with the [Standards. Town of Winter Park Standards and Specifications for Design and Construction \(Standards\).](#)
- B. **Requirements Aand Standards Ffor Street Improvements.** The following street improvements shall be provided in each new subdivision in accordance with the requirements and standards specified as follows:
1. *Pavement.* In all new subdivisions, public and/or private streets shall be paved with an approved hard surface material such as asphalt, concrete, or other similar permanent hard surface material. All street paving designs shall be approved by the Town Engineer.
  2. *Safety.* Streets shall be designed and engineered to be safe and efficient for all users and all modes of travel (e.g., motor vehicles, bicycles, pedestrians, service vehicles, emergency services, and transit, including people with disabilities). The design and layout of streets shall consider the routing of bicycles to and through the proposed development.
  3. *Pedestrians and Cyclists.* The Town may permit off-street facilities for pedestrians and cyclists to be substituted for on-street accommodations, provided that the proposed facilities provide equal or better access, mobility, and safety for pedestrians and cyclists.
  4. *Waiver of Specific Accommodations.* The Town may waive specific accommodations within the right-of-way if the Town Engineer and the Director find that, due to the physical location of the street (e.g., on a very steep slope in an infrequently traveled location), the expected short and long-term benefits of the accommodation will be substantially outweighed by the estimated costs of its implementation and continuing maintenance.
- C. **Integration.** New streets shall integrate into the existing street pattern so as to:
1. Address the new development's access and circulation needs;
  2. Provide a pattern of streets that facilitates mobility and provides a choice of routes and travel modes, in that:
    - a. Existing and planned streets (including streets that are shown on pending applications for development approval on the abutting property) are continued in a similar alignment on the parcel proposed for development and at a comparable right-of-way and pavement width unless the Town Engineer finds that:
      1. There is a demonstrated need to change the street cross-section in order to improve the safety of the traveling public (all modes), or to provide on-street parking in areas where it is appropriate;
      2. The right-of-way or pavement section of the existing street is substandard;
      3. The continuation would create incompatibility or materially concentrate through-traffic in residential neighborhoods; or
      4. Conditions of topography or geology make the continuation of the right-of-way alignment infeasible or undesirable in terms of initial construction or continuing operations and maintenance.
    - b. When a tract is subdivided into larger than normal building lot(s) or parcel(s), such lot(s) or parcel(s) shall be arranged so as to permit the logical location and opening of future streets and appropriate resubdivisions, which include adequate utility easements and connectors for such resubdivision.
  3. Facilitate Town-wide and regional traffic movements (where higher-order functional classifications are involved).

- D. **Character.** New streets shall correspond to and reinforce the community character of the district(s) in which they are constructed.
- E. **Natural Resources.** Streets shall be located with appropriate regard for topography, creeks, wooded areas, and other natural features that enhance attractive development, or that are locally or regionally significant for their natural resource value.
- F. **Snow Storage.** Streets shall be designed to accommodate snow storage in a manner that does not interfere with the use of sidewalks and bicycle lanes. For specific snow storage standards, see Sec. 6-F-3, *Snow Storage Standards*.
- G. **Street Lighting.** Street lighting shall be installed by the developer in accordance with Sec. 6-E-3, *Outdoor Lighting*.
- H. **Utilities.** Rights-of-way shall be sufficient to accommodate underground utility lines and shall be laid out in the template provided in the Standards.
- I. **Driveways.** Driveways shall be installed in accordance with the Standards.
- J. **Sidewalk Design**
  - 1. *Generally.* The pedestrian system is made up of a range of on- and off-street facilities including sidewalks, paved and unpaved multi-use trails and side paths, and natural surface trails. Pedestrian access and circulation shall be provided as required by this Section and the Town's Standards as determined by the Town Engineer.
  - 2. *Dimensions and Location.* Sidewalks shall be provided on both sides of the street when it is deemed to be topographically feasible.
  - 3. *Separation from Street.* New, expanded, and reconstructed sidewalks shall be separated from the street by a planting or landscape strip when a planting or landscape strip is a component of the applicable street cross-section.
  - 4. *Design and Grade.* Sidewalk, crosswalks, and/or trails shall provide a continuous circulation system and be designed to minimize conflicts among vehicles, pedestrians, and bicyclists. The design and grade of sidewalks and curb ramps shall be compliant with the Americans with Disabilities Act (ADA).
  - 5. *Surfacing.* Sidewalks shall be surfaced with concrete according to the Town's Standards.
  - 6. *Curb Ramps.* Curb ramps shall be installed as follows:
    - a. At intersections, a curb ramp shall directly face the crosswalk in each direction. See Figure 4-A-5, *Illustrative Curb Ramp Configurations*.
    - b. In order to facilitate pedestrian access onto the sidewalk, curb ramps shall be provided at crosswalks and accessible parking spaces.
    - c. Curb ramps shall be designed and constructed according to the Town's Standards.

Figure 4-A-5  
Illustrative Curb Ramp Configurations

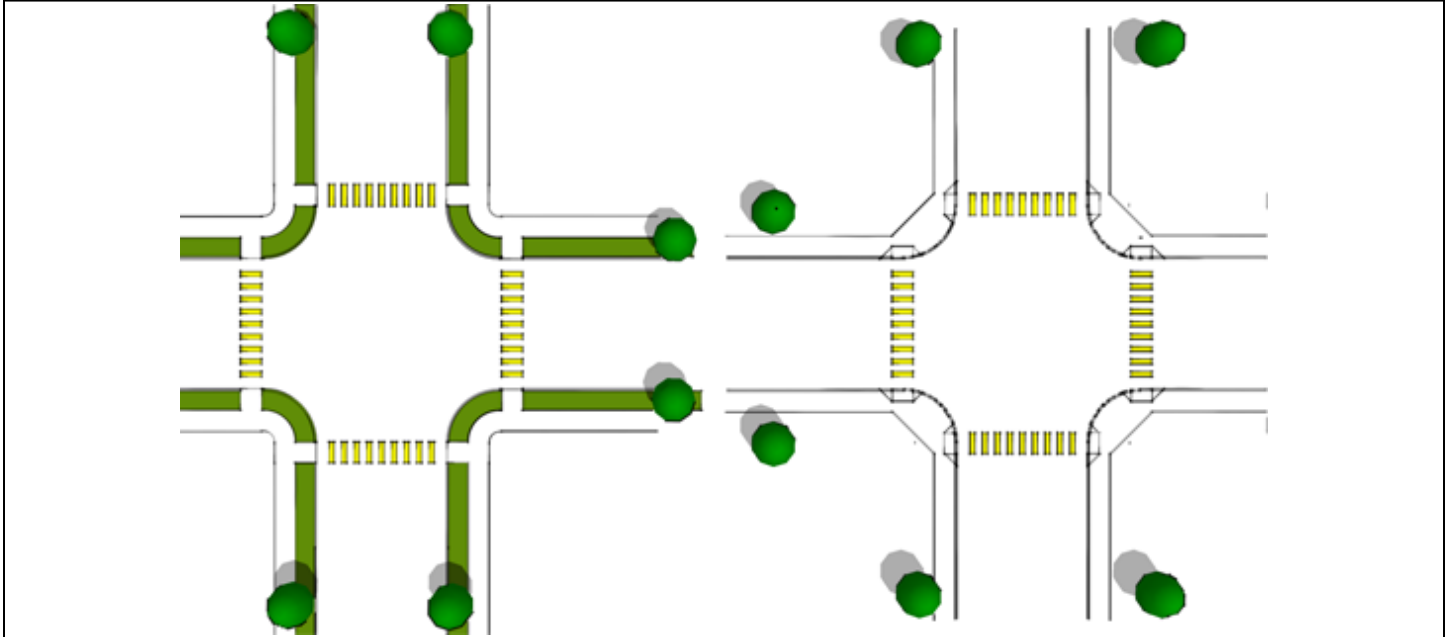

- K. **Curbs, Gutters, and Sidewalks.** Curbs, gutters, and sidewalks may be required where the Town Engineer deems them necessary for the proper drainage of stormwater or for the protection of public safety and welfare.
- L. **Street Name Signs.** Refer to Sec. 4-A-13, *Street Naming and Addressing System*.
- M. **Removal of Combustible Materials and Other Debris.** All combustible materials and other debris, including fallen trees and stumps, shall be removed to avoid disease and fire hazards.
- N. **Trails.**
1. *Generally.* Off-street shared-use trails shall be developed in accordance with the Comprehensive Plan and the Community Trails Plan to link major attractions and destinations throughout the Town, including the neighborhoods, resort areas, parks, schools, libraries, employment centers, and shopping areas.
  2. *Easement.* Development that abuts a linear corridor that is identified in the Comprehensive Plan and the Community Trails Plan shall provide an easement for the construction of a trail in accordance with the plan.
  3. *Maintenance.* Maintenance responsibilities shall be established at the time of a preliminary plat. See Sec. 7-E-5, *Preliminary Plat*.

#### Sec. 4-A-6 Blocks

- A. **Block Length.**
1. *Minimum.* Blocks shall be a minimum of **four hundred feet (400') feet** in length.
  2. *Maximum.* Blocks shall be a maximum of **600'-six hundred feet (600')** in length.
- B. **Block Width.** Blocks shall be wide enough to allow two **(2)** tiers of lots with an appropriate depth.
- C. **Block Shape.** The following concerns shall be addressed when determining the exact shape and layout of a block network for a subdivision:
1. The provision of adequate building sites;
  2. The need for convenient access, control, and safety of vehicular and pedestrian traffic; and

3. The limitations and opportunities presented by the topography on the site.

#### Sec. 4-A-7 Lots

---

- A. **Generally.** Lot area, width, depth, shape, and orientation shall:
1. Be appropriate for the location of the subdivision, the development, and the use contemplated;
  2. Facilitate the placement of buildings with sufficient access, outdoor space, privacy, and views;
  3. Provide safe and convenient public and emergency access from either a public or private street; and
  4. Avoid any foreseeable difficulties, for reasons of topography or other conditions, in securing building permits to build on all lots.
- B. **Area.**
1. When sanitary sewer and water facilities are not available in Grand County Water and Sanitation District No. 1 or Winter Park Water and Sanitation District, lots shall be of sufficient size to conform to all applicable County and State health regulations.
  2. The area of lots within the Town must meet the minimum standard for the district set out in Table 3-A-3, Residential Lot and Building Standards, or Table 3-A-5, Non-Residential Lot and Building Standards.
- C. **Corner Lots.** Corner lots shall have:
1. ~~For lots at collector or arterial street intersections or at any acute-angle intersections, Aa~~ radius or diagonal tangent of ~~fifteen feet (15')~~ 15-~~or twenty feet (20')~~20-feet, respectively, must be provided on the final plat. ~~for lots at collector or arterial street intersections or at any acute-angle intersections,~~
  2. A greater width than the minimum required to provide for the street side setback to be of equal depth to the required front yard.
- D. **Through Lots.** Through lots shall be avoided to the maximum extent practicable. Where essential to separate residential development from arterial street right-of-way, the Planning Commission may deviate from this standard provided the condition was not due to the applicant or owner.
- E. **Lots to be Further Subdivided.** Whenever a parcel of land is subdivided and the subdivision plat shows one (1) or more lots containing more than one (1) acre of land and the Director deems that it is more likely than not that such lots will eventually be resubdivided into small building sites, the City shall require that such parcel of land allow for the future opening of streets and the ultimate extension of adjacent streets. Easements providing for the future opening and extension of such streets shall be made a requirement of the plat.
- F. **Floodplain.** See Article 5.B, Flood Hazard Reduction.

#### Sec. 4-A-8 Easements

---

- A. **Generally.** During development approval, the Town may require a variety of easements on private property or lots. These easements may be for any of the following, or other approved, purposes:
1. Drainage;
  2. Utilities;
  3. Access to public utilities or drainage areas;
  4. Fire protection or hazard mitigation;
  5. Police protection and other emergency services;
  6. Solid waste removal;
  7. Pedestrian access; and
  8. Natural resource or open space conservation.

- B. **Standards and Specifications.** All easements shall be designed and constructed in compliance with the [Standards. "Town of Winter Park Standards and Specifications for Design and Construction."](#)
- C. **Utility Easement Width and Location.** Where required, all lots shall provide utility easements for sewer, water, gas, drainage, electricity, cable, fiber-to-the-home, or other public utilities that are necessary or desirable to serve the subdivision or lot. The width and location of the easement shall be such that access, maintenance, repair, or reconstruction can be accomplished without undue hardship to the utility. Easement standards may be included in the standard subdivision specifications promulgated by the Town Engineer.
- D. **Drainage Easements.** To the extent practicable, existing surface drainage patterns serving any off-site properties of two (2) or more proposed lots or parcels shall be protected by easements or open space. In addition, drainage easements shall be placed on lots to convey surface water to storm sewers located on the street or to surface drainage channels located in easements or open spaces as topography and grading dictate.
- E. **Fire Protection Easements.** Rear fire protection access easements, where necessary to provide adequate protection for the structure, shall be improved as appropriate for fire protection equipment, at a minimum width of twenty feet (20'), with appropriate turning radii for the Town's fire protection equipment as determined by the East Grand Fire Protection District No. 4.
- F. **Pedestrian Access Easements.** Pedestrian access easements may be required in accordance with Sec. 4-A-5, *Streets, Sidewalks, and Trails*.
- G. **Conservation Easements and Open Space.**
  - 1. The regulations of this UDC may allow the creation of conservation easements to preserve open space and protect natural resources.
  - 2. Conservation easements shall exclude other easements that would result in the disturbance of the land, except that pedestrian access easements and non-destructive utility and drainage easements are permitted within areas protected by conservation easements.
  - 3. Conservation easements shall provide for permanent management and maintenance of the property by a responsible party other than the Town, such as a nonprofit land trust or property owners' association.
  - 4. ~~All conservation easement agreements, regardless of whether or not they are between public or private parties, shall be approved by the Town Attorney.~~
  - 5. For specific open space standards, see Sec. 4-A-9, *Open Space Standards*.
- H. **Encroachments and Removal of Encroachments.**
  - 1. No permanent encroachments of structures and no overhanging limbs, shrubbery, or vegetation of any kind shall be allowed to be located within the area of any easement required by this Section.
  - 2. While the Town or utility provider benefiting from the easement will make efforts to minimize disturbances, both shall have the right to remove any encroachment, structure, fence, landscaping, or other improvements placed upon or over such easement,
  - 3. The Town and/or utility provider shall not be obligated to restore or replace any such encroachment but shall restore any disturbed ground surfaces with seeding.
  - 4. The Town may assess the cost of removing an unauthorized improvement from an easement against the landowner, including the placing of a lien on the property.
- I. **Maintenance of Easements.** The responsibility for the regular maintenance of the ground surface in any easement shall rest with the owner of the property within which the easement exists.

## Sec. 4-A-9 Open Space Standards

---

- A. **Generally.** This Section provides standards for dedicated open spaces, which include recreational areas, common open space, stormwater management areas, and parks, as a function of subdivision development.
- B. **Principles.**



1. *Integrated Design.* Generally, open spaces shall be integrated into the subdivision to bring significant open space to the maximum number of properties, as well as visibility from public rights-of-way within the proposed development. Visual or physical access to open spaces may be limited if such limitations would materially enhance natural resource preservation and management.
2. *Trails and Drainage Corridors / Waterbodies / Watercourses.* Open space shall be designed to provide trails along drainage corridors, waterbodies, and watercourses. The landscaping along drainage corridors, waterbodies, and watercourses shall be designed to enhance the filtering of surface and subsurface water flows. Trails shall provide access along the drainage corridor or watercourse for the residents of the subdivision.
3. *Other Open Spaces.* Formal open spaces shall be designed to provide areas of enjoyment within the development. Landscaping, furniture, and other amenities for pedestrians shall be installed to enhance this effect.

**C. Special Site Considerations.**

1. *Shadow Protection.* When the subdivision abuts an area developed with or specified for taller buildings, the location of open space wherever possible shall be such that it will protect shorter structures from shadows cast by taller buildings.
2. *Unusable Land.* Steep, unstable or swampy land, and land subject to inadequate drainage, avalanche or rock slides, and geological hazards, shall be identified and unless acceptable provisions are made for eliminating or controlling problems which may endanger health, life, or property, such sites shall not be platted for residential occupancy. Land not usable for residential purposes may be set aside for open land uses as for parks, conservation areas or various agricultural uses.
3. *Areas of Flooding.* Any land subject to flooding or located in a natural drainage channel shall not be platted for occupancy until adequate provisions to eliminate or control hazards are made and approved by the Planning Commission. Areas subject to flooding may be left as open space or reserved as easements. These provisions shall be made to protect the health, safety and welfare of the public, as well as to eliminate any flood hazard resulting from the development of the area. The Planning Commission may require the developer to furnish appropriate technical data and other information necessary to determine applicability to and evaluations of developments on any land subject to flooding or located in a natural drainage channel. Technical data and other information requested by the Planning Commission will be prepared and certified by a professional qualified in the appropriate field of expertise. If it is determined that a proposed development or a portion thereof lies within a flood hazard area, said area shall not be used unless the following standards and prohibitions are complied with:
  - a. Storage or processing of materials that in time of flooding are buoyant, flammable, explosive, or otherwise potentially injurious to human, animal, or plant life, shall be prohibited.
  - b. Solid waste disposal shall be prohibited within flood hazard areas.
  - c. Development of any nature must be designed so as to prevent: substantial solid debris from being carried downstream, enlargement of a flood plain, or damage to lands other than those being proposed for development.
  - d. Structures proposed in a flood plain must be adequately floodproofed to or over one foot (1') above the maximum water elevation of an intermediate regional flood and be anchored to prevent floating, collapse, or lateral movement.
  - e. Development in a flood plain shall be consistent with the need to minimize flood damage.
4. *Outdoor Amenity Space.* Appendix A, Section I, *Outdoor Amenity Space and Features.*

---

**Sec. 4-A-10 Utilities**



- A. **General.** In general, utility systems shall be arranged as outlined in the "~~Town of Winter Park Standards and Specifications for Design and Construction~~Standards" and in such a manner to avoid cross connections, minimize trenching, and adequately separate incompatible systems.
- B. **Sewer Plans and Designs.**
1. Sanitary sewer plans shall comply with any and all applicable standards and technical procedures adopted by the Colorado Board of Health and the respective water and sanitation districts.
  2. Sanitary sewer plans other than on lot standards and technical systems shall comply with any and all applicable standards and technical procedures adopted by the ~~Colorado Board of Health~~Colorado Department of Public Health and Environment (CDPHE).
- C. **Water Supply.**
1. Water supply for new development shall be sufficient to provide for the development's potable water demand, irrigation needs, and fire protection needs. Water from water districts shall be supplied using fire-rated lines that are acceptable to the fire protection district, and installed to the specifications of the water service provider.
  2. Water supply systems shall be designed and located so as to minimize or eliminate infiltration and avoid their impairment during or subsequent to flooding.
- D. **Water Mains.** Water mains shall be installed in a subdivision which will provide an adequate water supply for domestic and firefighting purposes when the overall system is brought up to an acceptable standard set forth in the fire suppression rating schedule published by the Colorado Insurance Services Office.
- E. **Potable Water System.** The potable water system shall be connected to the water system of the appropriate water and sanitation district, shall be of sufficient size and design, and in the opinion of the Town Engineer, adequately supply water to each building to be erected in the development. The following requirements shall apply:
1. Water lines shall be designed to connect each lot with mains of not less than six inches (6") in diameter;
  2. Construction details shall be in accordance with the water and sanitation district specifications; and
  3. All water system installations shall be subject to all Town ordinances and agreements relating thereto.
- F. **Fire Hydrants.** Fire hydrants shall be installed at street intersections or as necessary to assure that no part of any building is located a distance in excess of one hundred and fifty feet (150') from the likely location of a fire engine as determined by the fire chief after consulting with the appropriate water and sanitation district. Fire hydrants shall be provided with adequate water pressure and volume for firefighting purposes and shall be located no more than three hundred feet (300') apart.
- G. **Sanitary Sewage System.** The sanitary sewage system shall be connected to the sanitary sewage system of the appropriate water and sanitation district and shall be of sufficient size and design to collect all sewage from all proposed or probable structures in the development. The sanitary sewage system shall otherwise be constructed and maintained in conformity with the requirements and standards of the ~~applicable~~ water and sanitation district.
- H. **Individual Sewer Service Connections.** Service connections (sewer "taps") shall be appropriately sized, installed and marked by stake for each building in a development at the time of construction of sewer improvements.
- I. **Telephone and Electric Lines.** Telephone, electric transmission lines, distribution feeder lines, communication trunk lines, television cables, and similar utility installations shall all be placed underground.
- J. **Other Utility Facilities.** Transformers, switching boxes, terminal boxes, meter cabinets, pedestal ducts, and other facilities necessary for fully functioning underground utilities may be placed above ground, but shall be adequately screened with approved planting material pursuant to [Article 6.C, Landscaping, Buffering, and Screening](#).

#### **Sec. 4-A-11 Stormwater Drainage**

---

- A. **Generally.** Stormwater drainage improvements shall be installed in each new subdivision in accordance with requirements and standards specified in the ~~Standards manual~~. The storm drainage system shall be of sufficient size

and design to carry off all predictable surface water runoff within the subdivision or development and stormwater drainage which enters the development from adjacent areas.

- B. **Adequate Rights-of-Way Required.** Whenever any public stream, waterbody, or surface drainage course is located in an area that is being subdivided, the applicant shall dedicate adequate rights-of-way that are sufficient to provide for the drainage course and access for the purposes of cleaning, widening, deepening, sloping, improving, or protecting the stream and for drainage maintenance.
- C. **Prohibited Encroachment.** Lots created along a drainage channel shall not encroach upon or into a drainage easement.
- D. **Required Review and Approval.** All design features for stormwater drainage in a development shall be subject to the approval of the Town Engineer. Should there be site-specific conditions that warrant or demand deviation from the above criteria, these considerations shall be reviewed by the Town Engineer. Such a request for deviation shall be made in writing with supporting documentation. Approval of any deviation from these specifications shall be made in writing by the Town Engineer. Cost alone shall not be sufficient grounds for approval of a deviation. The Director shall be notified in writing of any approved deviations from the specifications contained in this Section.

#### **Sec. 4-A-12 Permanent Reference Monuments**

---

- A. **Generally.** The applicant's registered professional land surveyor shall provide reference monuments and markers in the subdivision as required by the and based on North American Vertical Datum of 1988 (NAVD88).
- B. **Permanent Reference Monuments Marker.** Permanent reference monuments shall be located and placed within the subdivision or development as required by the [Colorado Revised Statutes \(C.R.S\), Title 38, Article 51, Section § 105, Monumentation of Subdivisions.](#)
- C. **Monuments Required.** Prior to issuance of a building permit the property owner shall provide a site plan showing compliance with C.R.S Title 38, Article 51, [§Section-105, Monumentation of Subdivisions.](#) The property boundaries shall have monuments installed in conformance with State Statutes.

#### **Sec. 4-A-13 Street Naming and Addressing System**

---

- A. **Generally.**
  - 1. All public streets shall be named and approved by the Director. Private driveways, accesses, and entrances shall not be named.
  - 2. The street naming and addressing system shall be maintained to facilitate the provisions of necessary public services (police, fire, mail, deliveries), reduce public costs for administration, and provide more efficient movement of traffic.
- B. **Applicability.** For consistency, this street naming and addressing system shall be adhered to on all newly platted, dedicated, and named streets, and for all newly numbered buildings or parcels. The Planning Division shall check all new street names for compliance with this system and issue all street addresses. Existing streets that are not conforming to this system shall be made conforming as the opportunity occurs.
- C. **Order of Naming Elements.** Streets shall be identified with a direction, name or number, and a street type, in that order. Illustrative examples are shown in Illustration 4-A-13-A, *Components of Street Identifiers.*
  - 1. Streets shall not be identified in a manner in which the street type precedes the street name or numbers (e.g., Avenue of Mountain View), unless:
    - a. The street is an extension of an existing street, and retains the name of the existing street; or
    - b. The name of the street is a Spanish phrase (e.g., "Camino del Rio") that does not include an English suffix (see Subsection E.7.a, below).

**Illustration 4-A-13-A**  
**Components of Street Identifiers**

Prefix Direction Element	Street Name or Number Element	Street Type Element	Suffix Direction Element
North	Main	Street	NA
East	Vasquez	Road	NA
NA	Willow	Way	NA
NA	Bear Trail	Court	East
NA	Snow Creek	Circle	West
Notes: NA = Not Applicable			

**D. Prefix Direction Elements.**

1. A prefix direction, indicating whether the street (or street segment) is East or West of Main Street can be considered where:
  - a. The street is numbered (instead of named); or
  - b. The street crosses Main Street.
2. In other situations, a prefix direction is optional, but if used, it shall follow the conventions in Subsection D.1, above.

**E. Street Name or Number Element.** Street names or numbers are always required, according to the following naming conventions:

1. The names of streets shall not exceed fifteen (15) characters, including spaces, unless the name represents a person, place, or event of historic significance to Winter Park.
2. Generally, a street shall only have one (1) name. However, U.S. Highways and Colorado State Highways shall be given their federal or state designations and may also have a local identifier.
3. Proliferation of similar street names (except numbers) within a subdivision or in the general vicinity is discouraged (e.g., Eagle Street, Eagle Lane, Eagle Court, Eagle Circle, Eagle Avenue, and Eagle Way in the same subdivision or small area).
4. Street names should be continuous through subdivisions or areas of Town where they align.
5. Blisters (cul-de-sacs without "necks") and spur roads shall have the same name as the street to which they are connected.
6. 4th order streets (see Table 4-2-2-13A, *Order of Streets*, below) are subject to the following additional conventions:
  - a. 4th order streets that align with 1st, 2nd, or 3rd order streets across an intersection shall have the same street name or number element and the same street type element as the street with which they are aligned.
  - b. 4th order streets that align with each other across an intersection (including a "T" intersection) shall have the same street name or number element (see Subsection F, below, for street type element requirements and Subsection G, below for suffix direction element requirements).
  - c. Disconnected 4th order streets that align with each other shall have substantially different names unless a connection between the streets is planned.
7. The following may not be used as street names:

- a. A word that is also a street type (e.g., Court Avenue), unless the word is a Spanish word (e.g., Calle, Camino, Avenida) and there is no English suffix in the street name (e.g., "Camino del Rio Street" is not allowed);
- b. A name that is already used elsewhere in Grand County on a different alignment;
- c. A name that is a homonym of, or easily phonetically confused with, a name that is already used elsewhere in Grand County (e.g., Main Avenue and Maine Avenue); or
- d. A name that includes hyphens, apostrophes, special characters, or other punctuation.

**F. Street Type Element.**

1. **Order of Streets.** All streets shall be assigned a functional classification according to **Section 4-2-2-2, Functional Classifications**. In addition, for naming purposes, streets shall be assigned an "order," based on their functional classification and level of connectivity, according to the standards of Table 4-A-13A, *Order of Streets*.

Table 4-A-13A Order of Streets		
Order	Functional Classification	Connectivity
1st	Arterial, Collector, or Local	Spans multiple blocks, usually beyond the boundaries of a single subdivision plat or parcel proposed for development
2nd	Local	Connects roughly parallel 1st order street, but does not span multiple blocks
3rd	Local	Circles and arc-shaped streets that connect to one street or two roughly perpendicular streets
4th	Local	Cul-de-sacs

2. **Assignment of Street Type Element.** Street types shall be assigned based on the general alignment and order of the street, according to the standards of Table 4-A-13-B, *Assignment of Street Type Element*.

Table 4-A-13-B Assignment of Street Type Element				
Street Type	General Alignment			Order
	North-South	East-West	Multi/Other	
Boulevard	X	X	NA	1
Parkway	X	X	NA	1
Avenue	X	NA	NA	1
Drive	X	NA	NA	1
Street	X	NA	NA	1
Way	NA	X	NA	2
Lane	X	NA	NA	2
Place	NA	X	NA	2
Loop	NA	NA	X	3
Circle	NA	NA	X	3
Square	NA	NA	X	3
Court	X	X	NA	4
Point	X	X	NA	4

**TABLE NOTES:**  
 X= Applicable  
 NA = Not Applicable

**G. Suffix Direction Element.**

1. A suffix direction is required where:
  - a. The street terminates in a cul-de-sac at both ends, with an intersection in the middle, in which case the suffix direction shall indicate which side of the intersection the street segment is located on; or
  - b. The street is a circle or comparable curvilinear street that intersects with another street in two (2) separate locations, in which case the suffix shall be used to divide the street into up to four (4) sections, based on their location in the circle or arc.
2. A suffix direction is not allowed in other circumstances.

**H. Variations.** Should situations arise that are not covered in this Section, street names will be determined by the Director in coordination with emergency service departments and service-providing agencies (police, fire, post office, etc.).

**I. Addressing Conventions.**

1. South and east sides of streets are to receive addresses ending in even numbers;
2. North and west sides of streets are to receive addresses ending in odd numbers; and
3. Half addresses (e.g., 15 1/2 3rd St.) are not allowed.

## Article 4.B. Development Improvement Dedications, Agreements, and Guarantees

### Sec. 4-B-1 Purpose

---

The purpose of this Article is to ensure that:

- A. New utilities are properly installed and inspected before being formally dedicated to or accepted by the Town;
- B. New development provides its proportionate fair share of regional improvements for public parks, public schools and other public purposes to the extent that the facilities will serve the future occupants of new development;
- C. All land, structures, and all appurtenances dedicated to or accepted by the Town meet the standards set out in this Article; and
- D. Necessary standards are adopted to fulfill the objectives of the East Grand County School District Fee in Lieu Development Calculation Study.

### Sec. 4-B-2 Applicability

---

This Article shall apply to all new development requiring:

- A. The dedication and acceptance of land, public improvements and/or appurtenances;
- B. Oversized or additional public improvements in excess of the capacity required to service the proposed new development; and
- C. The dedication of school and/or open land sites or the submittal of a fee-in-lieu amount instead of the required physical land site.

### Sec. 4-B-3 Dedications and Acceptance

---

- A. **Generally.** This Section applies to dedications of land, public improvements, infrastructure, or appurtenances required for the development of property in the Town of Winter Park and the subsequent acceptance of the improvement by the Town.
- B. **Dedication of Land and Public Improvements.**

1. *Required.* Dedication of rights of way for streets giving access to adjacent lands and adjoining dedicated streets, and drainage utility easements, shall be required.
2. *Approval.* All streets or highways for public use, and all plans, plats, and replats of land laid out in a subdivision or building lots, and the streets, highways, alleys or other portions of the same intended to be dedicated to a public use or the use of purchasers or owners of lots fronting thereon or adjacent thereto, shall be submitted to the Planning Commission and Town Council for ~~approval~~ **acceptance** before they are recorded.
  - a. Previous approval of a subdivision ~~shall~~ **does** not constitute an acceptance by the Town of the streets, highways, alleys, or other public lands as indicated for dedication on the plat **unless otherwise specified on the plat.**
  - b. The dedication of any of these lands for public use of any nature within the Town shall be accepted by the Town only by specific action of the Town Council.
3. *Form of Dedications and Guarantees.* All dedications shall be made by a legal instrument approved by the Town Attorney. Dedications of park and school sites shall be shown on the plat for the proposed development. Other dedications shall be shown on the site plan or plat unless the Town determines that another form of dedication (e.g., a recorded easement) is more appropriate.
4. *Open Space Parcels.* Land areas that are used to satisfy open space ratio requirements shall be shown as separate parcels on plats. The open space parcels shall be restricted to open space uses by plat restrictions or separately recorded covenants, conditions, and restrictions.
5. *Public Facilities.* Reference shall be made to the Comprehensive Plan ~~in order~~ to determine general locations for various public facilities. Dedication of such sites and land areas shall be made at the time of final platting in one of any combination of the following ways:
  - a. By dedicating to the Town a Municipal corporation, in fee simple, on the final plat; or
  - b. By granting the land areas in fee simple on general warranty deeds to the Town.

**C. Timing of Dedication and Commencement of Construction.**

1. *Building Permits.* No building permit or certificate of occupancy shall be issued for any parcel or plat of land which was created by subdivision after the effective date of, and not in conformity with, the provisions of this UDC.
2. *Excavation of Land.* No excavation of land or construction of any public or private improvements shall take place or be commenced including the installation of roads, water, sewer and other utilities until after the Town Council has approved the preliminary plat, a development improvements agreement and a separate letter of credit or other acceptable collateral guaranteeing the completion of said improvements. Final construction plans shall be approved by the Town Engineer prior to ~~commencement~~ **commencing of** work.
3. *Completion.* A property owner/developer shall:
  - a. Complete construction of all required improvements within one (1) year from the date of the execution of the development improvement agreement. If such improvements are not completed within one (1) year, plus any approved extension, from the date of the execution of the development improvement agreement and in compliance with all approved plans, the cash deposit shall be retained or the letter of credit shall be drawn upon by the Town; or
  - b. Submit a letter to the Town Council requesting an extension of up to six (6) months to complete the required work. The extension request shall be submitted to the Planning Division prior to expiration of the original one (1)-year period or a previously granted extension period. The Town Council may grant the extension for good cause shown by the property owner/developer.
4. *Street Improvements and Maintenance.* The Town Council shall:
  - a. Withhold all public street improvements and public maintenance from all rights of way which have not been dedicated to the public and accepted for such purposes by the Town Council; and

- b. Require all roads be built to the Town Standards and Specifications for Design and Construction as a prerequisite to considering whether or not to accept a proposed street dedication.

**D. Dedication of Land for School Sites.**

- 1. *Residential Subdivisions Land Dedication Requirement.* All residential and mixed use developments/subdivisions shall provide for public school sites to serve the proposed subdivision and the future residents thereof in accordance with the following:
  - a. *Calculation of Land Area Dedication.* The size of school land dedications for residential and mixed use subdivisions shall be calculated as stated in Table 4-B-3, *School Land Dedication Calculations*.

Table 4-B-3 School Land Dedication Calculations	
Residential Development Type	Land Calculation Rate (per acre)
Single-Family Dwelling Units (Four (4) Units or Less/Fewer)	0.045
Single-Family Dwelling Units (Five (5) Units or More) / Multi-Family Dwelling Units	0.018

- b. *Dedication of Land Areas to the Town.* Dedication of such land areas shall be made at the time of final platting in one or any combination of the following ways:
  - c. By dedicating to the Town, a Municipal corporation, in fee simple, on the final plat; or
  - d. By granting the land areas in fee simple by general warranty deed to the Town.
- e. *Ineligible School Sites.* The following land areas shall not be acceptable in fulfilling the requirements for the provision of land areas for public school sites:
  - 1. Natural drainage ways, streams, gullies, and rivers including all lands within the one hundred (100)-year floodplain, unless the school district specifically accepts a certain portion thereof for a reasonable use and it is approved by the Town Council;
  - 2. Right-of-way and/or easements for irrigation ditches and aqueducts; and
  - 3. Steep or rugged land areas, hazardous geological land areas, hazardous wildfire land areas, and such other areas as are not conducive for use as school sites in the written opinion of the school district.
- f. *Required Improvements Abutting School Sites.* The developer/owner of the subdivision shall construct or install the following improvements on or abutting all designated school sites prior to the dedication of such land to the school district:
  - 1. Curb, gutter, and pavement, in accordance with the Town Standards;
  - 2. Utilities shall be extended to the property line; and
  - 3. All drainage structures and facilities.
- g. *Fee-in-Lieu.* The subdivider may request to pay a fee-in-lieu for the required school site dedication as opposed to reserving a physical site. See Sec. 4-B-6, *Fee-in-Lieu*.

**E. Dedication of Public Open Space.**

- 1. *Required.* A dedication, reservation, or conveyance of areas or sites suitable for public purposes such as parks, flood channels, scenic areas, and greenbelts of five percent (5%) of the total area of the subdivision shall be required.
- 2. *Location.* The location of all such areas or sites to be dedicated, reserved, or conveyed shall be mutually agreed upon by the applicant and the Town Council. The Town Council may consider recommendations from other public agencies which would be directly involved in the development and services of these areas.



3. *Method of Conveyance.* The type and/or method of dedication, reservation, or conveyance required shall be determined by the Town Council after recommendation by the Planning Commission.
4. *Fee-in-Lieu.* The applicant may request to pay a fee-in-lieu for the required public open space dedication as opposed to reserving a physical site. See Sec. 4-B-6, *Fee-in-Lieu*.

#### **Sec. 4-B-4 Development Improvements Agreement**

---

- A. **Generally.** This Section applies to any development improvements agreement required for the development of property in the Town.
- B. **Development Improvements Agreement.** Refer to Title 9, Chapter 1 in the Town's Code of Ordinances.

#### **Sec. 4-B-5 Reimbursements**

---

- A. **Generally.** This Section applies to any cost recovery or cost sharing agreement required for the development of property in the Town.
- B. **Public improvement Cost Recovery and Cost Sharing.** Refer to Title 9, Chapter 2 of the Town's Code of Ordinances.

#### **Sec. 4-B-6 Fee-in-Lieu**

---

- A. **Generally.** This section provides the amounts, calculation, and processes for the payment of fee-in-lieu fees that are applicable when chosen by a developer instead of the provision of physical school and/or open space land sites.
- B. **School Site Fee-in-Lieu Amount Calculation.**
  1. When the dedication of sites and land areas for school needs are not reasonably necessary to serve the proposed subdivision and future residents thereof because of the size, location, proximity to existing facilities, topography or nature of the proposed development, the Town Council, upon recommendations from the East Grand School District and other affected entities, shall require, in lieu of such dedication of land, the payment in cash by the applicant of an amount not to exceed the **fullfair** market value of such sites and land areas. The **fullfair** market value of an acre of property shall be multiplied by the land calculation rates of Table 4-B-3, *School Land Dedication Calculations*.
  2. The **fullfair** market value shall mean the current market value of the unimproved land after completion of platting. Such value shall be set annually by the Town Council via resolution on a per acre basis after considering recommendations from the School District and other appropriate parties. The same value per acre shall be used throughout the Town.
  3. If the applicant does not agree with the established value per acre, the applicant may submit the report of a qualified appraiser who is M.A.I. (Member Appraisal Institute) certified, which establishes a different value. The Town Council shall review the report and determine if such appraised value is reasonable. Based upon its review of the applicant's appraisal, and all other relevant information available to it, the Town Council shall then determine the value of such land for purpose of payment of cash in lieu of dedication.
- C. **Open Space Fee-in-Lieu Amount Calculation.**
  1. A payment in lieu of dedication of land for parks and open space may be accepted **if** in the event the Town Council determines that park or municipal land is not needed within the area of development due to the size of the development or proximity of other parkland, or the area of development is not needed by the Town to implement the park and recreation element of the Comprehensive Plan.
  2. The payment in lieu of land dedication shall not exceed five percent (5%) of the fair market value of the subject real property as determined at the date of final platting.
    - a. Fair market value shall be determined by mutual agreement between the subdivider and the Town Council.

- b. If the applicant does not agree with the established value per acre, the applicant may submit the report of a qualified appraiser who is M.A.I.--(Master Appraiser Institute) certified, which establishes a different value. The Town Council shall review the report and determine if such appraised value is reasonable. Based upon its review of the applicant's appraisal, and all other relevant information available to it, the Town Council shall then determine the value of such land for purpose of payment of cash in lieu of dedication.

**D. Payment of Fee-in-Lieu.**

1. Payments shall be made to the Town of Winter Park.
2. Payments shall be required at the time of submission of a final plat/final condominium as-built plat for recording with the Grand County Clerk and Recorder's Office.
3. When no subdivision is required for the proposed development and no dedication has been paid, the payment in lieu of land dedication shall be payable at the time of issuance of building permit.
4. Such funds shall be deposited by the Town in special interest-bearing accounts. Each deposit shall be credited to the name of the subdivision for which the payment is made.
5. The status of this account shall be reported annually to the Town Council.

**E. Fee-in-Lieu Withdrawals.**

1. *Withdrawal of School Site Fee-in-Lieu Payments.* Funds may be periodically withdrawn from the special account by the Town Council upon the request of the East Grand School District.
  - a. *Use of Funds.* Funds shall only be used for:
    1. Acquisition of reasonably necessary sites for the construction of school facilities;
    2. For the construction of employee housing required by the School District;
    3. For the purchase of employee housing required by the School District; or
    4. For the development or capital improvements to school sites within the **TownSchool District**.
    5. If housing units are purchased, a deed restriction restricting their use to School District employee housing shall be required and ownership shall remain in the name of the School District.
  - b. *Request for Funds.* The East Grand School District shall present in writing a plan for the funds detailing the project for the funds and the estimated budget. The request shall be presented to the Town Council for approval by resolution.
2. *Withdrawal of Open Space Site Fee-in-Lieu Payments.* The open space fee-in-lieu payment fund shall be used by the Town for one (1) or more of the following purposes:
  - a. Physical improvements to municipal parks and open spaces;
  - b. Acquisition of materials, including, but not limited to, trees, shrubs, benches, park equipment, and maintenance equipment for use in maintaining municipal parks and open space;
  - c. Preparation of drawings, renderings, and specifications for improvements to existing park areas within the Town; or
  - d. Purchase of land for parks, trails, open space, scenic preservation easements, and historic preservation purposes.