

Rules and Regulations

Prepared For



Winter Park Water and Sanitation District

March 2026

Prepared By

AECOM

Denver, CO

Table of Contents

Winter Park Water and Sanitation District Rules & Regulations

General Sections

- I. General Policy, Purpose and Definitions
- II. Special District Provisions
- III. District Organization
- IV. Water and Wastewater Service Provisions
- V. Plan Submittal and Review Requirements
- VI. Fees, Rates, and Billing Procedures
- VII. Discretion / Variance / Amendment

Technical Sections

- I. Construction Procedure
- II. Cross Connection Specifications
- III. Water Main Specifications
- IV. Water Service Specifications
- V. Irrigation Specifications
- VI. Sanitary Sewer Main Specifications
- VII. Sanitary Sewer Service Line Specifications
- VIII. Wastewater Pumping Stations Specifications

Appendix

Standard Details:

- G-1 Pipe Encasement Detail
- G-2 Trench Detail
- G-3 Reinforced Pipe Encasement Detail
- G-4 Trace Wire
- W-1 Water Service Installation, Single Family Residence
- W-2 Water Service Installation, Multi-Family or Commercial Development
- W-3 Fire Hydrant Setting Detail
- W-4 Service Line, Stop box, and Inside Meter Installation for Single Family Residence
- W-5 Valve Box Installation
- W-6 Concrete Kickblocks Bearing Surfaces and Installation
- W-7 PRV Vault
- W-8 Pipe Insulation Detail
- W-9 Restraint Rod Splice
- I-1 Common Area Irrigation Meter
- S-1 Single Family Residence Sewer Service Connection Detail
- S-2 Outside Drop Manhole
- S-3 Sewer Manhole
- S-4 24" Manhole Ring and Cover
- S-5 Grider Pump Connection Detail

Table of Contents

Winter Park Water and Sanitation District Rules & Regulations

S-6 Grease Interceptor

Table of Contents

Winter Park Water and Sanitation District Rules & Regulations

Exhibits:

- A Equivalent Single Family Unit Assessment Schedule
- B Fee Schedule
- C Application for Water and Wastewater Service
- D Service Area Definition
 - D.1 Vicinity Map
 - D.2 Service Area Map
- E Application for Water and Sewer Main Plan Review
- F Certification of Substantial Completion
- G Certification of Final Completion
- H District Equipment & Personnel Charges
- I Preconstruction Meeting Agenda
- J Progress Meeting Agenda

General Sections

Section I General Policy, Purpose, Definitions

- A. Policy - It is hereby declared that the following Rules and Regulations are in the public interest, will serve a public use, and will promote the health, safety, security and general welfare of the inhabitants within the Winter Park Water and Sanitation District.
- B. Purpose - This District is organized to provide facilities to distribute potable water, and to collect and treat domestic wastewater for its customers.
- C. District Contacts:
- | | |
|----------------------------|--------------|
| Administration Office | 970-887-2970 |
| Water Treatment Plant | 970-726-9221 |
| Wastewater Treatment Plant | 970-726-5041 |
- D. Definitions
1. District shall mean the Winter Park Water and Sanitation District.
 2. Board shall mean the Board of Directors of the Winter Park Water and Sanitation District.
 3. Shall, whenever it is used in these Rules and Regulations is mandatory, and may be construed to be permissive.
 4. District Manager shall mean any person hired by the District to have general supervision over the administration of the affairs, properties and business of the District.
 5. Superintendent shall mean any person hired by the District to maintain the water and wastewater plants, water and wastewater lines, and to enforce these Rules and Regulations.
 6. Office Manager shall mean any person hired by the District for the purpose of performing administrative duties and maintaining District records and accounts.
 7. District Engineer shall mean any qualified engineer certified and licensed in the State of Colorado, hired by the District for the purpose of designing and/or inspecting work for the District performed by contractors or individuals.
 8. Water Mains are generally defined as follows: Water mains are water pipelines that serve multiple properties and/or form a loop that reinforces the primary water distribution system. Water mains must be designed, constructed and maintained in conformance with District Rules and Regulations.
 9. Sewer Mains are generally described as follows: Sewer mains are sanitary sewer pipelines that serve multiple properties. Sewer mains must be designed, constructed and maintained in conformance with District Rules and Regulations.
 10. District Water and Sewer Mains must comply with the requirements of water mains and sewer mains as defined in District Rules and Regulations. District water and sewer mains must also be located in dedicated Town of Winter Park public right-of-way or within approved utility easements dedicated to the District. District water and sewer mains are owned, operated and maintained by the District.
 11. Private Service Lines are generally water and wastewater lines other than lines classified as District Mains, described above. The decision as to the classification of a water or wastewater line (main or service line) shall be at the sole and absolute discretion of the Board.
 12. Equivalent Single Family Unit (ESFU) - An equivalent single family unit is a

description of the water and wastewater demand equivalent to a detached home, defined herein as up to three bedrooms, two bathrooms and one kitchen, and usage based on 350 gallons of water per day. The Board may adopt by resolution an equivalent unit schedule for use in assessing plant investment fees (also known as tap fees). Whenever, in the opinion of the Board, an establishment classified as a unit, by the criteria set forth here or outlined in Exhibit A, represents more than normal unit water or wastewater load, such establishment may then be reclassified by the Board on the basis of water use, or by population count, or by any other fair and equitable method of unit determination devised and employed by the Board at its discretion. Disputes relating thereto shall be submitted by the property owner to the Board for hearing.

13. Regulation of Usage - Whenever there is a shortage of water or some other emergency, the Board shall have the power to regulate and curtail water usage.
14. Liability - No claim for damages shall be made against the District by reason of the following; damage to water heaters, boilers, appliances, or other personal property resulting from shutting water off, or turning it on, or inadequate or sporadic pressures; or damage caused by water escaping from open or defective faucets; damage caused by burst service pipes or other facilities not owned by the District. Any person violating any of the provisions of these Rules and Regulations shall become liable to the District for any expense, loss, or damage occasioned by reason of such violation. In collection of such expense, the Board shall be entitled to all costs of collection including interest at 12% per year from date of accrual, and attorney's fees.
15. Interpretation - Any dispute as to the interpretation of these Rules and Regulations or as to their application in any given case, shall be submitted to the Board of Directors and their decision shall be absolute and final.

Section II Special District Provisions

- A. The Winter Park Water and Sanitation District was organized in July of 1966 under the Statutes of Colorado. The District continues to operate as a Special District in the State of Colorado and is granted authority and special provisions as outlined in Colorado Revised Statutes, as amended.
- B. Resolution 1992-4-1 was adopted by the Board establishing guidelines for a new classification known as Commercial-Inactive. This Resolution was rescinded 2/13/02.
- C. In January of 1995, the District adopted a Resolution establishing the Winter Park Water and Sanitation District Enterprise and authorizing the Enterprise to have and exercise certain powers in furtherance of its purposes.
- D. The Board adopted Resolution 1995-5-1 approving a Loan Agreement with the Colorado Water Resources and Power Development Authority and readopting the Rules and Regulations (1986 edition) as amended in this Resolution.
- E. Pursuant to C.R.S. 32-1-1006 (1)(b)(1), the Board has adopted Resolution 1998-10-1 finding it is infeasible, impractical and undesirable to provide water and wastewater lines and facilities to certain parts of the District. See Service Area Definition and Maps attached as Exhibit D
- F. In the event the District changes the above policy (General Section 11.E.), which restricts its service area, the following provisions shall be applicable:
 - 1. Where it is desirable to provide water and sewer service to lands outside the District, it will be necessary prior to providing such service to extend the boundaries of the District to include said lands. The costs of the inclusion will be paid by the person making application for such inclusion, as hereinafter provided.
 - 2. The procedure for inclusion is provided by statute. That procedure is abstracted here in order that the person seeking inclusion may be advised of the principal requirements:
 - a. Person desiring to include lands outside the District should first contact the District Manager in order to determine whether or not the District's facilities are capable of serving such property.
 - b. Once it is determined that the District's facilities may be capable of serving such lands, the person making the application for inclusion (known as the petitioner) will provide a complete and accurate legal description of the property to be included to the Board on such forms as are prescribed by law. A sample may be obtained from the District's attorney. The petition must be submitted by 100% of the fee owners or owner and acknowledged in the same manner as required for the conveyance of land. The petition shall be accompanied with a minimum \$500.00 deposit.
 - c. The District's attorney will then review the petition to be certain it meets legal requirements. The petition will be presented to the Board at its regular meeting, and the applicant may attend such meeting if desired to formally present the petition. Once presented to the Board, the petition will be publicized in a newspaper circulated within the District, setting forth the time and place for a formal hearing on the petition.
 - d. Upon completion of the publication and payment of required fee, the

Board will take final action on the petition, and if approved will cause the District's attorney to seek a Court decree ordering the petitioned property into the District. A certified copy of the Court order is then recorded in the County Clerk and Recorder's Office, at which time the property becomes included within the District's boundaries. The entire process takes approximately 60 to 90 days after the petition has been initially submitted to the Board. However, if the Board deems it necessary to negotiate terms and conditions on inclusion, it will take longer. All inclusions shall be in the discretion of the Board based on Colorado statutes and ability to provide service.

G. Inclusion Fees

1. Each application for inclusion of property into Winter Park Water & Sanitation District, regardless of size or area thereof, shall be accompanied by a payment of \$500.00 being a fee for the requisite processing of the application, including the giving of published notice of its filing and hearing thereon. None of such application fee shall be refundable to the applicant.
2. Each application for inclusion of property of greater than one acre in size shall be accompanied with the payment of a sum of dollars equivalent to \$800.00 as multiplied by the number of total and fractional acres of land sought to be so included and specifically described upon the petition for inclusion of the property, exclusive of public roads. In no instance, regardless of size of the property so described, shall such inclusion fee be less than the sum of \$500.00. In the event that the petition for inclusion is denied by the Board of Directors, the total amount of the inclusion fee deposited with the District will be refunded, but only unto the named petitioner and applicant for the inclusion and making the payment at the time of the application for inclusion.

H. All annexations will be required to provide adequate water rights, both in quantity and quality, as well as location to service their development.

Section III District Organization**A. Directors, Powers, and Meetings**

1. The property and business of the District shall be managed by the Board of Directors who shall be elected and otherwise chosen pursuant to, and shall exercise the powers granted by law, particularly the Colorado Special District Act hereafter amended. The officers of the District shall be the officers of the Board and shall be elected and otherwise chosen as hereinafter provided.
2. The Board shall meet regularly on the second Wednesday of each month. No notice to the Board shall be required in connection with such regular meetings. Public notice of the time and place designated for regular meetings shall be posted in at least three (3) public places within the District and the Grand County Courthouse, Hot Sulphur Springs, Colorado, such notices to remain posted and to be changed in the event that the time and place of such regular meeting is changed.
3. Special meetings of the Board may be called at any time by any officer or member of the Board, in accordance with the Colorado Special District Act, and notice of such meetings shall be given to the Directors by letter, postcard, telephone call, or personal notice, and at such time prior to the meeting as under the circumstances may be practical. Notice of the time and place of such special meeting will be posted in at least three (3) public places within the limits of the District and at the Grand County Courthouse in Hot Sulphur Springs, Colorado, at least three (3) days previous to said meeting. Business of the Board shall be conducted only during such regular or special meetings, and all meetings shall be open to the public.
4. A special meeting of the Board shall be held at such time as the notice thereof may specify.
5. Three (3) members of the Board shall constitute a quorum at any meeting.
6. Failure on the part of any member of the Board of Directors to attend three (3) consecutive meetings, either regular or special, shall cause the Board of Directors to consider and decide by the regular voting procedure whether such absent member shall continue in his/her tenure as a member of the Board of Directors, in accordance with the Colorado Special District Act.
7. So far as practical, Robert's Rules of Order, newly revised, shall be followed at meetings of the Board, except the Chairman/President shall vote on all issues.
8. Each member of the Board may receive as compensation for his/her service a sum to be determined in advance by resolution of the Board, not in excess of \$1,600.00 per annum, payable at the rate of \$100.00 per meeting or the maximum allowable amount set by Colorado statute. No member of the Board shall be interested in any contract or transaction with the District except as directly allowed and with disclosure as provided by State statutes.
9. Any vacancy on the Board shall be filled within 60 days by the remaining members of the Board as provided by Statute, the appointee to act until the next biennial election when the vacancy shall be filled by election.
10. The biennial election of the Directors shall be held in accordance with the Colorado Special District Act.

GENERAL SECTIONS

11. The Board shall have no authority to enter into any contract, or otherwise bind or obligate the District, to any liability for payment of money for any purposes, for which provision is not made in an appropriation resolution, including any legally authorized amendment thereto, in excess of the amounts of such appropriation for that fiscal year. Any contract, verbal or written, contrary to the terms of this subsection shall be void, and no District funds shall be expended in payment of such contracts.
 12. The Board operates as an enterprise, pursuant to a resolution duly adopted by the Board.
- B. Officers, Employees
1. The officers of the District shall include a President, Vice President, Secretary, and Treasurer. The Board shall elect one of its members as Chairman of the Board of Directors and President of the District and another of its members as Vice Chairman of the Board of Directors and Vice President of the District. The Secretary, who may be a member of the Board, shall also be elected by the Board. The Secretary and Treasurer may be one person, but the Treasurer must be a Board Member.
 2. The regular election of such officers shall be held biennially at the first regular meeting of the Board following the biennial election of the Directors in such year. Any officer elected to fill a vacancy shall serve until the next regular election of officers.
 3. In the event of absence or inability of any officer to act, the Board may designate the powers or duties of such officer to any other officer, Director or person whom it may select.
 4. The District shall retain services of an attorney, engineer, employees, or other consultants as necessary and as allowed by statute. Employees of the District are hired and retained at will, and the Board retains the right to fire them at any time with or without cause unless a separate written employment agreement is entered into.
 5. The Board of Directors may appoint a manager to serve for such term and upon such conditions, including salary, as the Board of Directors may establish. The manager shall have general supervision over the administration of the affairs and employees and business of the District, shall be charged with the hiring and discharging of employees with appeal to the Board of Directors, and management of the District's properties.
 6. The selection of agents, employees, engineers, accountants, special consultants and attorneys of the District by the Board of Directors will be based upon the relative qualifications and capabilities of the applicants and shall not be based on political services or affiliations. Agents and employees shall hold their offices at the pleasure of the Board of Directors. Contracts for professional services of engineers, accountants, and special consultants and attorneys may be entered into on such terms and conditions as may seem reasonable and proper to the Board of Directors.
 7. Indemnification of Directors and Employees – The District shall defend, hold harmless and indemnify any director, officer, agent or employee, whether elective or appointive, against any tort or liability, claim or demand, whether groundless

or otherwise, arising out of any alleged act or omission occurring during the performance of duty. The District may compromise and settle any such claim or suit and/or pay the amount of any settlement or judgment rendered thereon.

a. For the purpose of this Section only, the following definitions shall apply:

Employee - The term employee means a director, officer or employee (hereinafter referred to as employee) of the District, whether or not compensated, elected or appointed. The term employee specifically excludes any person or organization contracting to perform services or acting for the District as an independent contractor.

Performance of Duty - The term performance of duty shall be interpreted as broadly as possible to include any situation in which a District employee could conceivably be deemed to be acting within the scope of his/her employment. It shall specifically extend to all employees who are providing service on a voluntary basis or otherwise to any private, corporate, or governmental party other than the District, when doing so with the appropriate consent and authorization from the District. The term performance of duty shall not include any act or omission constituting deliberate and intentional tortious or criminal conduct, or malfeasance in office, or willful or wanton neglect of duty.

b. The District reserves the right to designate the attorney appointed to defend an employee in any tort or liability action instituted pursuant to this Section.

c. The District agrees to indemnify an employee up to, but not to exceed, the amount of \$350,000 for any injury to one person in any single occurrence with an aggregate limit of \$900,000 for any injury to two or more persons in any single occurrence, or in the maximum amount otherwise specified under the Colorado Governmental Immunity Act (Article 10 of Title 24, C.R.S., as amended). The District specifically reserves any defenses which are made available to the District or its employees by said Governmental Immunity Act.

d. All claims to be paid pursuant to this Section shall be paid by the District or its insurer. Any judgment or settlement of a claim against the District shall be paid in accordance with the provisions of said Governmental Immunity Act.

e. No defense or indemnification shall be provided by the District to an employee in the following circumstances.

If the employee willingly and knowingly fails to notify the District, within a reasonable time, of any incident or occurrence which he/she might reasonably expect to result in a tort or liability claim against him/her or the District.

If any employee fails to notify the District of any notice of claim or summons and complaint served upon him/her commencing a suit for damages reimbursable pursuant to this Section. Such notice

shall be given to the District within five (5) business days of its service upon the employee.

If an employee fails to exercise reasonable effort to notify the District of any claim which is informally asserted against him/her for damages reimbursable pursuant to this Section.

If an employee refuses to cooperate with an investigation or defense of a lawsuit by the District, or its insurer, or by a private attorney employed by the District to furnish the defense to said employee, or a private investigator hired by the District to investigate such tort or liability claim.

- f. If the District or the employee against whom a claim reimbursable hereunder is asserted has any other valid insurance, bond or indemnification plan available covering the loss or damage alleged against him/her, such insurance, bond or other plan will be first applied to the payment of a claim. In such event, the obligation of the District to indemnify and hold harmless the employee shall exist only for liability incurred in excess of such other coverage.
- g. In the event of any payment made pursuant to this Section, the District shall be subrogated to the employee's rights of recovery therefore against any person or organization, and the employee shall execute and deliver instruments and papers and do whatever else is necessary to secure such rights of subrogation. The employee shall do nothing to prejudice such rights.
- h. No assignments of indemnification shall be permitted without the written consent of the District, signed by the President, and no such assignment shall bind the District unless such written consent is given prior to assignment. If, however, the employee shall die, the benefits of this Section shall be available to, and apply fully to, the employee's legal representative, but only while acting within the scope of his/her duties as such.
- i. Any defense and indemnification available to an employee under this Section shall continue to be available after the termination of his/her employment, office or tenure if the act of omission causing such liability occurred during the course of his/her duties while an employee of the District. Such defense and indemnification shall not be available to a former employee, however, in the event that the tort or liability claim against him/her is asserted as a counterclaim or set off in a suit brought by the employee, except the extent that the liability of such employee may exceed the amount of his/her own claim or suit.

- j. The provisions of this Section shall be subject to and, to the extent of any inconsistency therewith, shall be modified by said Governmental Immunity Act, as said Act is amended.
- C. Seal, Clerical, and Finance
1. The Board shall adopt a seal of the District to be used in all places and in such manner as seals are generally used by public and private corporations. The Secretary shall have custody of the seal and shall be responsible for its safekeeping and use.
 2. The Secretary shall keep, in a well-bound book, a record of all proceedings of the Board, minutes of meetings, certificates, contracts, bonds given by employees, and corporate acts, which shall be open to inspection during business hours by residents or property owners in the District, as well as other interested parties.
 3. Monies of the District shall be deposited in the name of the District in such bank(s) or government pool(s) authorized by State statutes, as the Board of Directors shall designate and as shall be authorized by law, and may be drawn out by transfer or on checks signed in the name of the District by such person(s) as the Board, by appropriate resolution, shall direct.
 4. The Treasurer shall keep strict and accurate accounts of all money received by and disbursed for and on behalf of the District in permanent records. Capital accounts and operation and maintenance accounts shall be segregated according to the methods specified and defined by the District Board by applicable laws of the State of Colorado, and budget and audit reports shall have separate schedules for the two types of accounts. Capital income shall include tap fees, bond sale proceeds, and government grants. The Board shall cause an audit or audits to be made of financial affairs of the District at the end of each calendar year in accordance with the Colorado Local Government Audit Law, and shall make the required publication thereof.
 5. The Board of Directors shall adopt an annual budget for the ensuing calendar year before the first day of each calendar year and shall cause a certified copy of such budget to be filed with appropriate State and Grand County officials as provided by the Colorado Special District Act and the Local Government Budget Law.
 6. The Board of Directors shall, before December 15 of each year and in the manner required by law, certify to the Board of County Commissioners of Grand County, Colorado, the rate of any ad valorem tax levy which the Board of Directors shall have fixed as the annual levy for the District.
 7. The officers of the Board of Directors shall perform such other duties and functions as may from time to time be required by the Board of Directors, by the Rules and Regulations of the District, or by special exigencies, which shall later be ratified by the Board.
- D. Bidding and Contracting Procedures
1. Except in cases in which the District will receive aid from a governmental agency, a notice shall be published for bids on construction contracts for work or material, or both, involving the expense of \$60,000 or more or as otherwise stated in the Colorado statutes. The District may reject any and all bids, and if it appears that the District can perform the work or secure material for less than the lowest bid, it may proceed to do so.

2. A Notice of Invitation to Bid shall be published in a newspaper of general circulation within District boundaries. The Notice will request sealed proposals for construction to be done, or for materials needed. The specifics of the contract will be stated; where and when plans and specifications may be examined; and the time and place the sealed proposals will be opened and publicly read.
3. The Board retains the right, in its sole discretion, to reject any or all proposals; determine the proposal and subcontractors that will serve the best interests of the District; and determine the proposal and subcontractor which is more responsible to perform the work.
4. Bids must be accompanied by an acceptable bidder's bond, or a certified check payable to the District in an amount equal to 5% of the bid. If, within the time designated in the Notice of Award, the contract is not executed, and if required, Payment and Performance Bonds and Certificates of Insurance are not provided, the District shall keep the bid bond as liquidated damages, and assess such other damages as the District may determine.
5. Payment and Performance Bonds are required for Contracts over \$50,000; and discretionary with the Board of Directors under that amount. (Sections C.R.S. 38-26-105 and 106.)
6. Five percent (5%) of all pay estimates shall be withheld during the construction and will be retained until the contract is completed satisfactorily, is finally accepted, and when accounting and publication, and total compliance with State statutes are met. For any amount exceeding \$150,000, the contractor may deposit acceptable securities in lieu of such retained amounts in accordance with law. (Section C.R.S. 24-91-105.)

Section IV Water and Wastewater Service Provisions**A. Applications, Permits, Fees**

1. Water and wastewater service will be requested via an application (see Exhibit C). Information packet and application are available from the District Office or the Town of Winter Park. Upon review of building plans, Equivalent Single Family Unit (ESFU) assessment and payment of plant investment (tap) fees, and approval of the application for service by the District Board of Directors, the building plans will be stamped “approved,” and the owner can obtain a building permit from the Town of Winter Park subject to other Town requirements.
2. The Board shall consider applications on a first-come, first-served basis. Application approval shall be contingent upon the District’s ability to provide the proposed service and still meet the requirements of their discharge permit, including projected standards and treatment requirements, and other state and federal regulations pertaining to the District.
3. Plan Review Fee
 - a. \$500 will be charged for each submittal of multi-family structure plans; fee to be paid upon submittal of plans.
 - b. \$125 will be charged for previously submitted plans which are the same design as an existing building; fee to be paid upon submittal.
 - c. A \$500 base fee will be charged for initial review of plans for a multi-lot commercial development; fee to be paid upon submittal. Beyond the initial plan review, \$250 will be charged for plan re-reviews, as determined by staff.
4. Plant Investment Fees (also referred to as tap fees) for both water and wastewater will be charged to users of the District based on an assessment of building plans. The Board reserves the right to modify, increase, decrease or change in any way the tap fees at any time. The current Fee Schedule is attached as Exhibit B. No guarantee can be made for service until tap fees have been paid, and service will be on a first-come, first-served basis. An Availability of Services letter will be issued for plat approval purposes but service cannot be guaranteed until tap fees have been paid. Tap fees are due and payable prior to issuance of any building permit by the Town of Winter Park. This allows the District to proceed with construction of necessary improvements in advance of need, as tap fee revenues are utilized for capital projects. Substantial construction must be started within one year from date of tap purchase. If the taps have not been put into use at the end of two years time, the taps will be canceled, service fees will be discontinued, and a credit in dollars equal to the amount paid for the taps will be given. The District will retain the funds paid for the taps. To obtain taps at a later date, it will be necessary to pay the difference between the credit and the current tap fee. These tap fees cannot be refunded or the taps transferred to another property. This provision is available only if the District has adequate capacity at the time applicant seeks to apply for new taps. Anyone not paying tap fees in a timely manner shall pay at the rate in effect when discovered, and back service fees will be due from the time the building permit was issued, or should have been issued,

- or the change in use occurred.
5. Water or Wastewater Main Extensions – Water or wastewater main extensions will be at the expense of the applicant. At the time of installation, a refundable amount, if any, will be agreed upon between the applicant and the District. It is the intent of the District to achieve equity between various parties utilizing the water and/or wastewater service. It will act as an impartial intermediary but will not guarantee the reimbursement. Water and wastewater line extensions will be designed by the District or an engineer approved by the District. Plans and specifications for water or wastewater line extensions will be reviewed in advance by the District.
 - a. Adjustment of Water Service Pressure – Adjustment of water service pressure (pressure increase/decrease) in service areas where the existing water main does not provide suitable water service pressure will be at the expense of the developer. The determination of the need for adjustment to water service pressures shall be determined by the District. Water booster pump stations, pressure reducing valve vaults, and associated facilities will be designed by the District or by an engineer approved by the District, in accordance with District design criteria. Design calculations, plans and specifications for these facilities will be subject to review by the District Board. Consideration of development in service areas where the existing water main does not provide suitable water service pressure shall be at the sole discretion of the District Board. See Detail W-7.
 6. Service fees per ESFU are determined by the Board of Directors and subject to change as necessary to meet the financial obligations of the District. The amount of service fees charged per account is based on the number of taps assessed. Service fees for both water and wastewater will commence the first of the month after tap fee payment is due and building permit issued. Water meter readings are taken toward the end of each month. Wastewater fees are a monthly flat rate. See Exhibit B for current monthly Service Fee rates for water and wastewater.
 7. Bonds/Loans /Retirement Fees – It is current District policy to review and adjust, if required, the amount of money necessary to retire District bonds and/or loans.
- B. Fire Protection – The number and location of fire hydrants in a given area is determined by the District and the East Grand Fire Protection District. When required in business and building group areas where increased fire protection is necessary, private fire mains and hydrants may be needed. Location of these fire mains and hydrants is to be determined by the Fire Protection District and reviewed by the District. Sprinkler system supply lines shall be considered private lines. Additional information is provided in Technical Section III - Water Main Specifications. If a fire hydrant is damaged, District personnel will coordinate the repair. The party responsible for damaging the hydrant will be invoiced for the cost of the repairs. Damaged hydrants need to be repaired as soon as possible.
- C. Irrigation - The District encourages water conservation and requests close monitoring of irrigation to avoid depleting water availability for domestic use. Water will be provided for irrigation purposes as District water capacity is available. The water supplied for irrigation is treated water. Owners must be conscientious when irrigating as great

quantities of water can be used in short time periods. Irrigation water does not return to the District's system as waste-water, therefore is not returned to the river; it is considered "consumptive" use. Natural landscaping is encouraged, i.e. landscaping which requires very little watering. There are specific types of grass and plants that grow better in high altitude and require less water, rock and/or bark can be used for ground cover. See Technical Section V – Irrigation Specifications.

- D. Transfer or Sale of Taps - Following are guidelines for the transfer or sale of taps purchased from the District by initial and future users. The District Board of Directors must authorize any sale or transfer.
1. Tap fees, when paid, give the owner of the designated property authorization to utilize the District's water and/or wastewater system, for the purpose, and under the conditions for which, the fees were paid, and under existing regulations as modified from time to time.
 2. The owner may transfer a tap to another property owned by him/her. Any right to the tap will be voided for the property from which it was transferred.
 3. Taps may be transferred from an existing building to another use on the same property provided the service is discontinued and the existing building destroyed. There will be no additional charge for the transferred ESFU(s). However, if additional taps are necessary, based upon an increase in ESFUs, the user will be charged at the current tap fee rate.
 4. Sale of taps from one person to another is prohibited, except with the transfer of land or improvements, as is otherwise described in this Section.
 5. If property with a tap or taps is sold, the taps will remain in effect for the new owner provided the service fee payments are kept current. Notification to the District of the sale of property is the responsibility of the purchaser and seller.
 6. The service charge assessed by the District per month must be paid and accounts must remain current.
- E. Hydrant Water Use – Fire hydrants are primarily for emergency use and must be operated by trained personnel. Some limited, pre-authorized use may be permitted, but only with prior District approval and instruction before use.
- F. Wastewater Pumping Stations -- Wastewater pumping stations are generally discouraged and will not be permitted within the District if option(s) exist for gravity wastewater service. See Technical Section VIII - Waste Water Pumping Stations for more details. For the purposes of this Regulation, the District will generally consider the gravity sewer alternative for service as viable if the total construction cost of the gravity sewer service is equal to or less than three times the total construction cost of the wastewater pumping station.
1. Wastewater pumping stations serving a single family residence, with total demand of less than 500 gallons per day, may be subject to different requirements than described herein, and the Owner should contact the District to determine the applicable requirements. If a wastewater lift station is determined by the District to be an acceptable means to provide wastewater service to the project area, the proposed lift station must be approved by the District and meet all requirements of the Colorado Department of Public Health and Environment and other applicable regulatory authorities. Proposed wastewater pumping facilities will be

- reviewed for consideration on an individual basis.
2. Wastewater pumping stations shall be owned, operated, and maintained by the property owner(s) served by the pumping stations. As part of the approval process for wastewater pumping stations, the operator must provide the District, on an annual basis, documentation that qualified personnel or firms are contracted to perform the necessary operation and maintenance procedures to assure the continued operation of the wastewater pumping station for the following year.
- The following note shall be placed on subdivision plans for lots that require wastewater pumping for service:
- “There is no gravity wastewater service to Lots XXX. A wastewater pumping station is required to serve the property.”*
3. On-site retention of wastewater for all wastewater pumping stations shall be provided. The size and capacity of on-site retention will be determined by pump station size, distance from wastewater treatment plant, and location of pump station site, etc.
 4. The station must be readily accessible for maintenance vehicles under all weather conditions. The facility should be located off the traffic way of streets and alleys. Security fencing and access hatches with locks shall be installed.
 5. Lift station materials and equipment shall be in accordance with District regulations and other applicable state and local regulations.
- G. Wastewater from Individual Septic Systems or temporary restroom facilities is not accepted by the District.
- H. Detrimental Effluents Prohibited
1. Toxic or non-biodegradable waste or any waste which may have a detrimental impact on the operation of the wastewater treatment plant, or may impact the ability of the District wastewater treatment plant to meet state permit discharge standards, shall not be discharged in the wastewater system. Oils and greases for mechanical uses, gasoline and kerosene shall not be discharged into the wastewater system. No foreign matter which could cause stoppage may be discharged from vehicle wash racks, filling stations, restaurants, or other building sewers, unless the discharge first passes through an acceptable grease, sand and oil interceptor.
 2. Grease removal or pre-treatment shall be required for any user who will generate a significant grease discharge (i.e. restaurant kitchen).
 3. No petroleum products may be discharged to the sanitary sewer.
- I. Cross Connection Control-The control of cross connections to prevent contamination of the water system is very important to protect the integrity of the system and safety of all water users. Refer to Technical Section II-Cross Connection Specifications.
- J. Transfer of ownership of mains and facilities shall be in accordance with Technical Section I, Part h-Ownership, and other applicable sections of the District Rules and Regulations.

Section V Plan Submittal and Review Requirements

- A. Engineering and Plan Review Procedure - The District will establish and amend from time to time procedures to be followed by developers, contractors, sub-contractors performing work on water and wastewater utilities. These procedures will include requirements for documentation, submittals, fees, engineering design, construction and acceptance. Minimum requirements for submittals for review of proposed facilities are as follows:
1. Three (3) sets of plans of the proposed development to include site plan showing project layout and location, including the following:
 - a. Legal description of property to be served.
 - b. Streets, rights-of-way and easements (existing and proposed), curbs, gutters, sidewalks, and property lines, section ties, etc.
 - c. Existing and proposed utilities – water, sanitary sewer, storm sewer and detention ponds, ditch and canal crossings, gas, phone and electric, and other surface or buried facilities. Show points of connection to the existing systems.
 - d. All plans shall include information on existing utilities in accordance with ASCE 38 and Colorado SUE law.
 - e. Show proposed service lines (water and wastewater), fire lines, meter pits and clean-out structures.
 - f. Show adjacent streets for reference to the site.
 - g. Plans should be submitted on 22” x 34” drawings.
 - h. North arrows shall point to the top or left of page.
 - i. Include the following notes on the drawings:
 1. *Only District personnel are permitted to operate valves and hydrants.*
 2. *Construction Water*
Construction Water Use – Construction water may be drawn from the building service line after tap fees have been paid. Such use must be through a meter, pressure-reducing valve (PRV) and reduced pressure zone (RPZ)-type backflow preventor. Only in exceptional cases, and with prior District approval, will construction water be provided from a fire hydrant and, even in these cases, the above components must be used.
Construction water may be obtained from the District’s construction water truck fill station. Water will be metered on site and the Contractor charged current rates. Contractor shall setup an account with the District prior to construction.
 3. *The District shall be contacted and approval of location granted prior to installation of water meters and readouts.*
 4. *All inspections shall be completed prior to backfill. Any work buried prior to inspection by the District will be re-exposed, at the expense of the contractor, to permit inspection by the District.”*
 2. Development Characteristics (on plans and/or separate 8-1/2" x 11" report). Type of land use to include residential, commercial, industrial, mixed-use. District

must receive acceptable submittal of development characteristics and preliminary water and sewer utility plans prior to a commitment to provide water and sewer service.

- a. Residential – density, type of unit (single family, town homes, condos, duplexes, etc.), pool and clubhouse complexes, etc.
 - b. Commercial – density, type of commercial use (retail, office, apartment, specialty, restaurant, etc.). The number of shops and foundation locations should be shown on the plans.
 - c. Type and quantity of water use and demand, type and quantity of wastewater discharged required for all type developments. Average and peak water and wastewater flow rates shall be provided.
3. Upon preliminary review of plans by the District, one set of plans will be returned for revisions, if necessary, and stamped by the District with appropriate instructions.
 4. Final Plans will be submitted to the District at the time of preliminary plat submission to the Town of Winter Park. The plans will be on 22” x 34” sheets in a scale ranging from 1” = 20’ to 1” = 100’ horizontal and 1” = 5’ vertical, and shall include the following:
 - a. Legal description of property to be served.
 - b. Streets, rights-of-way, easements, curbs, gutters, sidewalks, and property lines.
 - c. Existing and proposed utilities including water, wastewater, gas, phone, electrical, storm sewers, etc. Show in plan and profile views, indicating points of connection to the existing system.
 - d. Proposed construction plans shall indicate mains, valves, hydrants, manholes, appurtenances, including thrust blocks.
 - e. Pipe materials, diameters, lengths, depths, slopes, method and design criteria, and calculations for waterline thrust restraint will be indicated for each section.
 - f. Location and size of future water and wastewater services, meter locations and location of remote registers.
 - g. Plan and profile of proposed water and wastewater utilities including complete dimensions referenced to street center lines. Show proposed or existing crossings of water mains, along with existing ground lines and limits of proposed cuts and fills.
 - h. Construction record drawings shall be submitted to the District for the constructed project prior to consideration of acceptance of same by the District.
 - i. North arrow (pointing to the top or left of page), bar scale, professional engineer stamp, benchmarks and elevations shall be included on each sheet.
 - j. Itemization of quantities shall be shown on the cover sheet (i.e. L.F. of pipe by size and materials, number of valves, manholes, blowoffs, fire hydrants, etc.).
- B. Plan Review
1. The cost of the preliminary and final review by the District of the developer’s

plans, both engineering and legal, will be at the developer's expense.

- a. \$500 will be charged for each submittal of multi-family structure plans; fee to be paid upon submittal of plans.
 - b. \$125 will be charged for previously submitted plans which are the same design as an existing building; fee to be paid upon submittal.
 - c. A \$500 base fee will be charged for initial review of plans for a multi-lot commercial development; fee to be paid upon submittal. Beyond the initial plan review, \$250 will be charged for plan re-reviews, as determined by staff.
2. Upon receiving final approval and prior to the initiation of any work, three (3) copies of approved plans shall be submitted to the District. Following completion of construction and prior to the initiation of the one-year warranty period, one complete set of construction record drawings shall be submitted to the District. See Technical Section I - Construction Procedures for construction record drawing requirements.

C. Ownership

Transfer of ownership of mains and facilities shall be in accordance with Technical Section I, Part H-Ownership, and other applicable sections of the District Rules and Regulations.

Section VI Fees, Rates, and Billing Procedures

- A. Payment Responsibility – Bills for water and wastewater service will be sent to the address of the property owner, unless the District receives a request from the property owner that billing be sent to an address other than that of the property owner. Mailing of a bill for water and wastewater service to an address other than the owner shall in no way affect the power of the Board to enforce payment of charges by discontinuing service to the premises at which the charge arose.
- B. Billing – Service fee charges shall be billed monthly. Charges for turn on, service line repairs, tap fees, water used from a hydrant, etc. shall be billed separately. Bills are payable within 20 days of postmark or a reasonable penalty for delinquency may be assessed. Reasonable attorney’s fees and other costs of collection may be assessed.
- C. Liability for Payment – Until paid, overdue tap fees, service fees, and any other charge authorized by these Rules and Regulations shall constitute a first and perpetual lien on or against the property being served, and any such lien may be foreclosed in the manner provided by the Act under which the District was formed and other laws of Colorado, or may be certified for collection to the County Treasurer. If referred to the Treasurer for collection, the Treasurer’s fee shall be added to the amounts due to the District. Costs relating to said liens incurred by the District shall be paid by the property owner. The occupant and the property owner are jointly and separately liable to the District for charges for water and wastewater service and other charges authorized by these Rules and Regulations, including attorney fees, and the District may proceed to collect any amount due it by a court action, in addition to any other remedies available.
- D. Fees – The Board may, at its discretion, increase or decrease tap, service, and other related fees as it deems necessary for the best interest of the District, provided such fees are uniform for properties in the same classification. However, the Board may establish different tap fees, service fees, etc. for properties classified by type or quantity of use or classification of water or wastewater as permitted by State statute. The Board may review, at any time, the adopted Fee Schedule (Exhibit B). However, the Board shall review the total annual cost of operation and maintenance on an annual basis and will revise the system as necessary to assure equity of the service charge system established herein, and to assure sufficient funds are obtained to adequately operate and maintain the water and wastewater systems. No guarantee of service can be made unless tap fees are paid and service fee payments kept current. See Exhibit B, attached hereto, for tap fee and service fee rates. See General Section II - Special District Provisions (Resolution 1998-10-1) and Exhibit D for District boundaries and service area definition.
- E. Plant Investment (Tap) Fees – Plant investment fees are based on an Equivalent Single Family Unit (ESFU) assessment made by District staff from plans furnished by the owner or developer. Fees are due and payable prior to issuance of the Town of Winter Park building permit. This provision is to guarantee the property owner the connection to District water and wastewater services, and also prevent reservation and/or speculation of taps. Substantial construction must be started within one year from date of tap purchase. If the taps have not been put into use at the end of two years time, the taps will be canceled, service fees will be discontinued, and a credit in dollars equal to the amount paid for the taps will be given. The District will retain the funds paid for the taps. To obtain taps at a later date, it will be necessary to pay the difference between the credit and

- the current tap fee. These tap fees cannot be refunded or the taps transferred to another property. This provision is available only if the District has adequate capacity at the time applicant seeks to apply for new taps. Upon payment of the tap fee, or when same becomes due and payable, monthly service fees shall commence.
- F. Service Fees – Service fees are based on the ESFU assessed by District staff. Service fees will commence the first of the month following payment of tap fees. As a provision for construction, the District will charge a reduced minimum service fee rate of one-half the regular service fee rate for the first six months following payment of tap fees. The regular service fee rate shall be charged after the six-month period, or when the Certificate of Occupancy is issued, whichever ever comes first. Wastewater is charged at a flat rate per ESFU per month. Water is metered and fees charged based on a minimum gallonage allowance per customer, plus an added charge for gallons used over the customer’s minimum.
- G. Discontinuance of Service – Service for any application, including public fire protection and any other municipal use, may be discontinued for any of the following reasons:
1. For misrepresentation in application as to property or fixtures to be served.
 2. For the use of water or wastewater on any property for a purpose other than that described in the application.
 3. For adding to the property or fixtures or for changing the use to be made of the water or wastewater system without prior approval from the District.
 4. For failure to keep service lines and/or plumbing fixtures in good order.
 5. For non-payment of any fees or charges.
 6. Where two or more families, places of business, or offices in a single building are supplied with water and/or wastewater service through a single service line, and the owner of the building or his duly authorized agent fails or refuses to pay the bills for water and/or wastewater service when due, or fails or refuses to abide by Rules and Regulations of the District. No such action involving the shutting off of the water and/or wastewater supply of an innocent customer shall be taken without first affording the tenant of the premises opportunity to make a new application for supply of water and/or wastewater service through a separate service line or meter.
 7. Procedure for Discontinuance and Renewal of Service
 - a. If a service fee account is not paid by the 30th of the month, “past due” is stamped on the next invoice.
 - b. If the account is not paid before the next month’s billing, a letter of notification of the overdue account will be sent. This notification will warn the owner or occupant of the possibility of disconnection if the account remains delinquent. The owner or occupant is advised of a hearing to be held at the next scheduled District Board Meeting, where the Board will discuss possible disconnection due to non-payment of fees.
 - c. If the account remains delinquent until the following month’s scheduled Board Meeting and the owner or occupant does not appear before the Board at that meeting, then another notification is sent advising the owner or occupant of the following:
 - Delinquent monthly service charges
 - Late charges

- Disconnection fee (\$100)
 - Date of physical disconnection
- d. If no payment is received by the date of disconnection, the District will close the water service valve and may remove the water meter. A lien may be filed on the property.
- e. During the next 12 months, if renewal of service at the disconnected address is requested, the owner or occupant will be advised that the following must be paid:
- Delinquent monthly service charges
 - Late charges
 - Disconnection fee
 - Reconnection fee (\$100)
- f. At the one-year anniversary for the service being disconnected, the District classifies the address as ‘dormant.’ If service is now requested, both the water and wastewater service lines must be inspected by the District for serviceability and conformance with applicable standards and codes. In addition, the District reserves the right to withhold service to the address due to system capacity constraints that may exist at that time. The owner or occupant will also be advised of the following fees:
- Delinquent monthly service charges and late fees (the service charge total will include the monthly minimum from the time of disconnection to the time of reinstatement),
 - Disconnection fee, and
 - Service Reinstatement Fee (\$1,000 for each water tap and \$1,000 for each wastewater tap associated with the property). The Service Reinstatement Fee covers the District’s expenses of inspecting the dormant service lines and assists in mitigating additional costs incurred by the District to replace the lost monthly revenue which would have been utilized to meet operational and maintenance expenses and debt service obligations. This is viewed as liquidated damages to the District.
- g. At the second year anniversary of the service being disconnected, the owner loses any interest or rights in their taps. If service is requested for the future, the District will evaluate the property to determine the ESFU rating, and the associated water and wastewater tap fees in effect at the time of such request must be paid.

Section VII Discretion / Variance / Amendment

- A. It is recognized that Rules and Regulations of the District can not cover each and every case presented. This is especially true in this District, since any enlargements in the number of customers and any major development may have an unanticipated tremendous impact upon the limited number of customers already being served, as well as on the District's existing water storage, water treatment and wastewater treatment facilities. Accordingly, any new applicant is encouraged to contact the Board at the earliest possible time in order to ascertain the District's ability to serve, and the conditions that the Board will impose in order to provide service.
- B. These Rules and Regulations may be altered, amended, or repealed at any regular meeting of the Board of Directors or at any special meeting of the Board of Directors. Additionally, they shall be deemed amended as State laws are passed which are inconsistent with them, or which grant the District greater authority or power, and that law shall be automatically deemed included in these Rules and Regulations.
- C. The Board retains the right to vary the terms of these Rules and Regulations or waive provisions when, in the Board's opinion, it is in the best interest of the District to do so.

Technical Sections

Section I Construction Procedure

- A. Construction Requirements – Before the developer may proceed with construction, approval of the preliminary plat by the Town of Winter Park must be obtained. The developer shall also be responsible for providing proof of adequate construction easements for the proposed utility lines, including title commitment, if deemed necessary. Construction easements shall be submitted to the District in advance of commencement of construction. In addition to construction requirements contained in other portions of these Rules and Regulations, the developer and his contractor shall observe the following:
1. Consult the District in case of conflict in direction or missing guidance. District direction shall govern.
 2. Where Federal, ASTM, or any other standard specifications are referred to, or included by reference, the latest issue and/or amendment thereto published at the time of construction shall be incorporated in the project.
 3. Schedule a pre-construction meeting with District personnel. At this meeting, requirements for the specific job will be developed. See Exhibit I for required agenda.
 4. Weekly meetings are required throughout construction. See Exhibit J for weekly construction meeting agenda.
 5. Construction shall commence within 12 months of the approval date shown on the plans. If construction is delayed or suspended for more than 12 months, plans must be resubmitted for review and approval.
 6. No excavations for water or sewer construction are permitted between October 15 and May 1. These dates may be subject to change by the District due to the prevailing weather condition.
 7. The contractor shall obtain required road cut permits from the Town, County or Colorado Department of Highways before starting construction in the right-of-way governed by the above entities.
 8. Development phasing of any project must be shown on the initial drawing submittal and made a part of the application procedure. No phasing will be permitted unless this requirement has been adhered to.
 9. The work shall be surveyed and staked under the supervision of a licensed land surveyor in accordance with the approved plans.
 10. The District shall be notified at least 48 hours prior to start of work.
 11. The District shall be notified whenever it becomes necessary to open or close a valve on the existing water system. **ONLY DISTRICT PERSONNEL ARE AUTHORIZED TO OPERATE VALVES IN THE DISTRICT.**
 12. Fire hydrants may only be operated by District personnel. Fire hydrants may only be operated by the Fire Department in an emergency. Fire hydrants shall not be operated by the Fire Department for training unless prior approval from the District is obtained. Contractors shall not operate District valves.
 13. Water lines shall be chlorinated and hydrostatically tested in accordance with District regulations. See Technical Section III - Water Main Specifications and Technical Section IV Water Service Specifications.
 14. Sewer lines shall be tested in accordance with District regulations. See Technical Section VI - Sanitary Sewer Main Specifications and Technical Section VII -

Sanitary Sewer Service Line Specifications.

15. Work relating to water and wastewater lines shall be inspected by District personnel. New water mains will only be tapped for service lines after having been installed to the satisfaction of the District, chlorinated, flushed and pressure tested, and released by the District. No tapping of dry mains is allowed. All taps made by the contractor shall be performed under the supervision of District personnel.
 16. No work shall commence until the installing contractor has an approved set of plans from the District and current specifications in his possession. The District's approval will be for general conformity to the District standards and does not constitute blanket approval of dimensions, quantities and details of the material or equipment shown. Nor shall such approval relieve the contractor's or developer's engineer of his responsibility for errors contained in the drawings.
 17. The District shall conduct periodic inspections of the work to verify that materials are furnished and the work is performed in accordance with District standards and the approved plans and specifications. The contractor shall furnish reasonable aid and assistance required by the District for the proper examination of the materials and work. Work shall be performed in accordance with accepted workmanship practices and District standards. Any work not accepted by the District shall be redone until compliance with these standards is achieved.
 18. All materials shall be new and subject to the inspection and approval of the District at all times. Shop drawings for all materials to be incorporated into the work shall be provided to the District prior to installation, with sufficient time to permit the District to review the shop drawings. The District has the right to perform any testing deemed necessary to ensure compliance of the material with these standards.
 - a. No material shall be used before being inspected and approved by the District.
 - b. The District has the authority to reject defective or inferior materials and/or defective workmanship.
 - c. Failure on the part of the District to condemn or reject inferior materials or work shall not be construed to imply their acceptance.
 - d. Inspection or approval by the District shall not relieve the contractor from any obligation to perform the work strictly in accordance with the plans and specifications.
 19. Whenever defective materials and work are rejected, the contractor shall promptly remove such defective materials and construction from the job site and replace defective portions to the satisfaction of the District.
 20. The cost of the District's inspection of the developer's extension of water and wastewater lines will be at the developer's expense. The developer will be invoiced for the actual expense incurred by the District to inspect and witness the testing of the water and wastewater lines. See Exhibit E District Equipment and Personnel Charges.
- B. Construction Water
1. Construction Water Use – Construction water may be drawn from the building service line after tap fees have been paid. Such use must be through a meter, pressure-reducing valve (PRV) and reduced pressure zone (RPZ)-type backflow

- preventor. Only in exceptional cases, and with prior District approval, will construction water be provided from a fire hydrant and, even in these cases, the above components must be used.
2. Construction water may be obtained from the District's construction water truck fill station. Water will be metered on site and the Contractor charged current rates. Contractor shall setup an account with the District prior to construction.
- C. Protection of Existing Facilities
1. The contractor shall notify the Utility Notification Center of Colorado (UNCC) at 1-800-922-1987 prior to commencement of work to have facilities staked and located in the field in order to ensure there will not be interruptions of services during progress of the work.
 2. The contractor shall preserve intact any underground pipes or other utilities encountered during construction. The contractor shall be liable for damages done to such existing facilities and structures as herein provided and shall indemnify and hold the District harmless from any liability or expense including, but not by way or limitation, injuries, damages or repairs to such facilities. It shall be the responsibility of the contractor to verify the existence and location of all underground utilities along the route of the work. In the event that during construction it is determined that an underground utility conduit, including wastewater mains, water mains, gas mains, and drainage structures or any above ground utility facilities are required to be relocated, the contractor shall notify the utility owner well in advance of his approach to such utility so that arrangements with the District and/or owners of the affected utility can be made without delay to the work. Relocations will be done at the contractors/owners expense, in accordance with all applicable regulations.
- D. Bonding – New construction contracted by the District shall be surety bonded by the contractor in a dollar amount equal to the dollar amount of the construction contract to provide protection against the following situations:
1. Repairs performed by the District by reason of default by the contractor.
 2. Necessary repairs of damages caused by the contractor.
 3. Necessary repairs caused by installing defective material.
 4. Necessary repairs caused by poor installation techniques.
 5. Costs incurred by the District due to the contractor's failure to perform in accordance with these standards.
 6. To guarantee completion of work and payment of sub-contractors. For small contracts and emergencies, bonding may be waived.
- E. Approval of Construction Work
1. District personnel shall inspect water and wastewater utilities throughout installation, at the owner's expense. Upon completion of installation, the contractor shall schedule an inspection of the project with District personnel. ESFU assessment will be verified according to the original plans, and a punch list will be developed identifying discrepancies that relate to the water and wastewater utilities. This punch list shall be submitted to the contractor as well as to the developer.
 2. Contractor shall submit Construction Record Drawings to the District after work is completed. Drawings shall include the following:
 - a. Construction Record Drawings should be submitted on 22" x 34" drawings

- and submitted via PDF and Autocad.
- b. All lines must be resurveyed and locations shown.
 - c. Pipe sizes and materials.
 - d. Elevation of inverts in and out and rim of all manholes.
 - e. GPS coordinates of manholes, valveboxes, curbstops, etc.
 - f. For building projects Construction Record Drawings should include mechanical/ plumbing, utilities, site plan and floor plan. For multiple discipline projects, coordinate with the District for final deliverable requirements.
 - g. Letter certifying that the infrastructure was built in accordance with the drawings. The letter shall be stamped by a Professional Engineer.
 - h. Construction Record Drawings must be received and approved before a project is accepted for service by the District.
3. Initial approval of work will be given and a one-year warranty period shall begin, when the following items have been completed:
 - a. Punch list work has been completed
 - b. Easements have been reviewed and field verified
 - c. The developer's engineer has certified (via letter to the District) that the work was done in accordance with approved plans and specifications
 - d. Construction record drawings for utility lines have been submitted to the District.
 4. An exception to paragraph above, if a utility system for a land development project is installed first, with the construction and occupancy of the dwelling units occurring at a later time, the one year warranty period that the owner/developer shall provide to the District will be started at such time that the Town of Winter Park issues the certificate of occupancy for the structures involved.
 5. The District shall send a letter to the owner stating the date of the beginning of the one-year warranty period.
 6. Just prior to the end of the one year warranty period, a final inspection will be scheduled and a punch list will be prepared by the District and will be sent to the owner. Upon completion of this punch list work to the satisfaction of the District, the District will send a letter to the owner stating final approval of the work.
 7. Any repairs needed on the system during the warranty period shall be the responsibility of the owner, and be completed in a timely manner. Corrective work shall have been performed and approved prior to final acceptance. Any repair shall extend the warranty for that repair for one year.
- F. Special Conditions – Where special conditions not covered by these specifications exist, detailed drawings and specifications shall be submitted to the District for approval before contracts are awarded or work begins. Written approval from an authorized representative of the District must be obtained before any materials other than those materials specified in these standard specifications may be employed in the construction of water and wastewater lines connected to or made a part of the water and wastewater system of the District.
- G. Utility Easements and Public Rights-of-Way – Water and wastewater mains and facilities shall be installed in existing public rights-of-way within the District. If a right-of-way is not available, an easement, as approved by the District, shall be required. The costs of acquiring rights-of-way or easements for mains and service lines shall be paid by the

TECHNICAL SECTIONS

applicant, including any costs which may be incurred by the District.

H. Ownership

1. All mains, when installed and attached to the District mains and facilities by any person other than the District, shall become the property of the District upon completion of the following:
 - a. completion of construction
 - b. Testing and final acceptance in writing by the District
 - c. Conveyance and transfer title for the mains and facilities to the District
 - d. Easement and easement drawing for the mains and facilities in a form acceptable to the District which has been prepared by a registered professional land surveyor in the State of Colorado, recorded with Grand County, showing the easement is clear of encumbrances
 - e. Insured title commitment policy and proof of clear title
 - f. Bill of Sale

I. Operation and Maintenance

1. District Main Line Maintenance - The District shall be responsible for the maintenance of its water and wastewater lines designated as mains, pressure reducing valve vaults, and appurtenances upon their dedication and acceptance. A water or wastewater line laid in an easement, which is classified by the Board as a main, shall be owned and maintained by the District. Decision as to the classification of a water or wastewater line (main or service line) shall be the sole and absolute discretion of the Board.
2. Service Line Maintenance - Property owners shall be responsible for the maintenance of the entire service line serving them, from the building to the point of connection with the water and wastewater main, even though a portion of the service line may be in the public right-of-way outside the limits of the property being served. It shall be the responsibility of the property owner to keep water and wastewater service lines in good operating order, repair leaks, line breaks, blockages, and vandalism to service line appurtenances. The curbstop valve should also be maintained; it must be operational and accessible.
3. Leaks – Any leak in any pipe or fixture on the premises of consumer shall be immediately repaired. Service may be discontinued until such repair is made.
4. Damages – The District shall in no event be responsible for maintaining any service line owned by the consumer, nor for damages done by water and wastewater escaping there from, nor for defects in lines or fixtures on the property of the consumer. The consumer shall at all times comply with Rules and Regulations of the District and the Colorado Department of Public Health and Environment relating to the service lines.
5. Water Meters – Water service shall be metered and the meter and accessories are provided by the District. The meter shall be owned and maintained by the District.
6. Backflow Preventers – If the District requires a backflow preventer for the property, the District will determine the necessary type and provide the backflow preventer. The property owner owns the backflow preventer and is responsible for maintenance; annual testing and inspections are required. Refer to Technical Section II-Cross Connection Specifications for additional requirements.
7. Inspection – Pipes, meters and fixtures shall be subject to inspection by the

- District or its duly authorized agents, at reasonable times.
8. Authority of Inspectors - Inspectors and other duly authorized employees of the District with proper credentials shall be permitted to enter upon all properties at reasonable times within the District as necessary for the purpose of inspection, observation, measurement, sampling, and testing, and repairing water and/or wastewater lines. District personnel are authorized to order suspension of work on District facilities if District personnel determine that defective materials are being used or if inferior workmanship is taking place. Any materials, workmanship, or methods the District determines are defective must be repaired or replaced to the satisfaction of the District prior to any connection to District facilities. This requirement also applies to work on private facilities that are connected to, or utilize, District water or wastewater facilities. District does not assume responsibility for work taking place on private property.
 9. Detrimental Effluents Prohibited
 - a. Toxic or non-biodegradable waste or any waste which may have a detrimental impact on the operation of the wastewater treatment plant, or may impact the ability of the District wastewater treatment plant to meet state permit discharge standards, shall not be discharged in the wastewater system. Boils and greases for mechanical uses, gasoline and kerosene shall not be discharged into the wastewater system. No foreign matter which could cause stoppage may be discharged from vehicle wash racks, filling stations, restaurants, or other building sewers, unless the discharge first passes through an acceptable grease, sand and oil interceptor.
 - b. Grease removal or pre-treatment shall be required for any user who will generate a significant grease discharge (i.e. restaurant kitchen).
 - c. No petroleum products may be discharged to the sanitary sewer.
 10. Manufacturing and Industrial Uses - Manufacturers and industries are prohibited from using the District wastewater system unless they make application to the District for the Board's consideration, the granting of which is discretionary. Said application will define the conditions, including pre-treatment limitations and restrictions, and the fees and charges determined by the Board to be in the best interest of the District and its inhabitants

Section II Cross Connection Specifications

The Colorado Cross-Connection Control Manual has been adopted by the District. The following are excerpts and do not represent the complete Manual.

A. DEFINITIONS

As used in the drinking water regulations:

(14) “Certified Cross-Connection Control Technician” means a person who has responsibility for the testing, operation and maintenance of cross-connection containment devices and is certified in accordance with the provisions of Article 12 of this regulation.

ARTICLE 12 - HAZARDOUS CROSS-CONNECTION**1. AUTHORITY**

Section 25-1-107, 25-1-108, 25-1-109, and 25-1-114, C.R.S., 1973, as amended.

2. CONTROL OF HAZARDOUS CROSS-CONNECTIONS

a. A public water system or a consecutive distribution system of a public water system shall have no uncontrolled cross-connections to a pipe, fixture, or supply, any of which contain water not meeting all applicable provisions of the drinking water regulations.

b. A supplier of water shall protect the public water system from contamination in the following manner:

3. Identify potentially uncontrolled hazardous service cross connections.

4. Require system users to install and maintain containment devices on any uncontrolled hazardous service cross connections, provided the Department has determined that the device is consistent with the degree of hazard posed by the uncontrolled cross connection.

5. Installation of containment devices shall be approved by the Water Supplier upon installation.

6. All containment devices shall be tested and maintained as necessary on installation and at least annually thereafter, by a Certified Cross-Connection Control Technician.

a. Water suppliers shall retain maintenance records of all containment devices. These records shall be available for inspection by Department personnel, per section 1.3 of these regulations. All maintenance records shall be kept for three years.

b. Any water supplier shall notify the Department of any cross-connection, as defined by Section 1.2.2 (10) of the drinking water regulations, within 10 calendar days of its discovery. The cross-connection shall be corrected within 10 days of being ordered in writing by the Department to correct the problem. Failure to do so may result in an enforcement order.

c. Violations shall be subject to the provisions and penalties prescribed by section 25.1.114 and 25.1.114.1 C.R.S., 1973, as amended, and to such other actions as provided by law.

B. Testing of Backflow Prevention Devices

1. When backflow prevention devices are installed, the Contractor shall notify the District so that arrangements can be made for District personnel to observe the

TECHNICAL SECTIONS

#

- device. New installations must be tested within ten (10) days of installation and annually thereafter, with a copy of the report sent to the District.
2. It shall be the duty of the property owner to have a Certified Cross-Connection Control Technician perform an inspection, and to conduct operational tests at least once a year. In those instances where the District deems the hazard to be great enough, the District may require certified inspections at more frequent intervals. These inspections and tests shall be at the expense of the property owner and shall be performed by a Certified Cross-Connection Control Technician. These devices shall be repaired, overhauled, or replaced at the expense of the property owner whenever said devices are found to be defective. Records of such tests, repairs, and overhauls shall be kept, with copies going to the District.
 3. Any entity that is required to have a Backflow Preventer Inspection shall do so no later than August 1st of that year or thirty days after being notified of the requirement by the District, whichever is sooner. If the entity fails to do so, then the District may retain a qualified Backflow Preventer Inspector who shall perform the inspection and that cost will be billed as part of the service fee and paid for by the owner of the property. The District shall have the right to collect the cost in the same manner provided for service fees in these Rules and Regulations and also as allowed by State Statute including reasonable attorney fees and other costs.

#

Section III Water Main Specifications**A. General**

These Specifications provide requirements for water main design and construction. No excavations for water or sewer construction are permitted between October 15 and May 1. These dates may be subject to change by the District due to the prevailing weather conditions.

B. Related Requirements

District standard details are located in the Appendix of these regulations.

C. Design Criteria**1. Design Flow/Pipe Sizing**

- a. Water mains shall be ductile iron and shall be sized large enough to provide for domestic, irrigation, and fire protection flows to the service area. The design flows should be in accordance with the District's schedule for Equivalent Single Family Unit flow rates (see Exhibit A, Note No.1) and the fire protection flow requirements of the Insurance Services Office.
- b. The maximum allowable headloss for mains is two (2) feet per thousand feet of main at max hour flow rate. The minimum pressure at max hour flow shall be 40 psi. Water mains shall be a minimum of eight (8) inches in diameter.

2. Design Pressures

- a. Water mains pressure reducing valve vaults and appurtenances shall be designed in accordance with AWWA criteria, these rules and regulations and shall be rated to the operating pressure as designated by the District.
- b. District shall be consulted prior to design/construction.
- c. If a PRV is required reference Detail W-7.

3. System Layout

- a. Whenever possible, water lines should be located on the north or east side of a dedicated street and should follow the alignment of the street in a reasonable fashion. If it is not possible to make the installation in a dedicated street, the water line may be installed in easements and rights-of-way granted on forms satisfactory to the District. Water lines and sewers must have a minimum horizontal separation distance of 10 feet. Vertical separation between sewer and water lines shall be 18 inches minimum, measured to the outside of the pipes. District personnel must inspect and approve prior to backfilling.
- b. Water lines shall have minimum cover of nine (9) feet.
- c. In-line valves are required every 500 feet and as required by the District. In addition, tees must have a valve on two (2) of three (3) branches and a cross must have a valve on three (3) of four (4) branches. Valves shall be located five (5) feet from the tee or cross.
- d. When water mains are designed in such a way that a dead end exists at the edge of a development or at the boundary of a filing within a development, the main shall be terminated with a fire hydrant. Dead end pipes are only permitted after prior approval of the District. When a new extension is

- connected to an existing main not terminated with a valve, the new main must have valve at the connection in order that the entire, newly constructed system, may be isolated. Under no circumstances shall a valve be located in concrete areas such as sidewalks, cross pans, aprons, curbs, or gutters. A temporary fire hydrant is required at the end of water mains which terminate at the development boundary in streets that will be extended at a future date. When the main is extended, the temporary terminal hydrant may be relocated. Permanent and temporary main dead ends shall be mechanically plugged, restrained and thrust blocked.
- e. A temporary blow off assembly may be used at the end of a temporary main dead end only if approved by the District. Blow off assemblies consist of valves, pipes, and materials necessary to install the blow off valve complete in place.
 - f. A fire hydrant is required at the end of mains extended into cul-de-sacs.
 - g. Fire hydrants shall be installed at locations prescribed by East Grand Fire Protection District. Each hydrant will have a gate valve isolating the hydrant from the water main.
 - h. The fire hydrant shall be located within the right-of-way and on the same side of the street as the water main unless otherwise specified by the District. No obstructions shall hinder the operation of the fire hydrant.
 - i. Fire hydrant branch lines shall be set at 90-degrees to street mains. The hydrant shall be set at the end of the branch line and shall face the branch line. No horizontal bends or offsets shall be used in installing fire hydrant branch lines. Under no circumstances shall any size or manner of tap be made on a fire hydrant branch line. A 6-inch gate valve shall be restrained to the tee on the main in order that the hydrant may be removed from the system for maintenance without affecting the distribution system. District personnel must inspect and approve prior to backfilling.
 - j. Air and vacuum relief valves may be required by the District at high points in a line to bleed air out of the line and to allow air to enter the line should a break occur. Air vacuum valve manholes will be in accordance with District standards.
 - k. Provisions also need to be made to drain the line at the lowest point, either by installing a fire hydrant or a blow off assembly.
4. Thrust Restraint
- a. Bends, tees, hydrants, dead ends, or other pipeline components which develop an unbalanced thrust shall be restrained by using thrust blocks and either harness rods, mega lug-type restraints, or a pipe manufacturers' restrained pipe system. If a mega lug restraint ring is re-used, it must be with District inspection and approval. These restraint systems shall be designed to withstand the thrust produced at the pipe test pressure.
 - b. Design pressures, flows, pipe sizes, thrust restraint and system layout is subject to review by District staff.
- D. Materials and Construction
- 1. Water Line Installation
 - a. Materials, including pipe, fittings, valves, hydrants, and other water line

appurtenances shall be new and shall be installed in accordance with the manufacturers' instructions. District personnel must inspect and approve all work outlined in this Section prior to backfilling. During installation, care shall be taken to prevent foreign material from entering the pipe. These preventive measures shall include plugging pipe openings with mechanical pipe plugs whenever pipe-laying is not in progress, and at the end of each day.

2. Water Pipe
 - a. Water line pipe shall be ductile iron meeting the requirements of AWWA C-151 with nominal laying lengths of 18-feet or 20-feet. The pipe wall thickness shall be determined according to AWWA C-150, but the pipe shall not be less than Class 52. Pipe furnished shall have 'push-on' type joints (AWWA C-111), however other joint types are acceptable if specifically approved by the District.
 - b. Pipeline fittings shall be cast or ductile iron, Class 250, meeting the requirements of AWWA C-104, C-110, and C-111. If the working pressure exceeds 250 psi, fittings shall be Class 350. Fittings shall have mechanical joint ends conforming to the referenced standards, with mechanical joint bolts and nuts manufactured from low alloy steel known as "Cor-ten", or approved equal. Flanged pipe shall not be used in buried service.
 - c. Pipe and fittings shall have a cement mortar lining in accordance with AWWA C-104.
3. Pipe Polywrap
 - a. Ductile iron pipe shall be enclosed in high-density, cross-laminated polyethylene film conforming to AWWA C-105. The pipe polywrap shall be secured to the pipe with tape prior to installation in the trench.
4. Valves
 - a. Valves must meet applicable AWWA standards. Water line valves four (4)-inch through 12-inch shall be resilient seat gate valves rated to 250 psi working pressure. Buried valves shall have mechanical joint ends, two (2)-inch operating nut, and shall open counter clockwise.
 - b. Valves shall be furnished with an operator extension that comes to within two (2) feet of the surface. The extension shall be manufactured of heavy one (1)-inch bar stock. The extension shall be held centered in the valve box with a centering disk.
5. Valve Boxes
 - a. Valve boxes shall be six (6)-inch cast iron adjustable screw-type, complete with valve box base. See detail W-5.
 - b. Valve boxes must be installed vertical and in such a manner that no load is transmitted from the valve box to the valve. Any boxes installed incorrectly must be reset.
 - c. Valve box tops located in the traveled portion of the roadway shall be set ½ -inch below finished grade in paved areas and four (4) inches below grade in gravel areas.
 - d. Backfill shall be compacted in maximum 6-inch lifts. If hydrant is not

- plumb, contractor shall reset.
6. Fire Hydrants
 - a. Fire hydrants shall be Mueller Super Centurion 250 (No. A-423) with two 2-1/2 inch and one 5-inch pumper nozzle and 6-inch mechanical joint shoes. Nozzle threads, nozzle cover, and operating nuts shall be National Standard. Hydrants shall be a **Mountain Standard, Mountain Bury-type** hydrant (9-foot minimum cover, **and one piece upper stem and one piece lower stem.**) See Detail W-3.
 - b. Fire hydrants shall be painted with Hydrant-Hide Red epoxy paint. Fire hydrant guard posts shall be installed when required by the District. Guard posts shall be painted with yellow epoxy paint after construction is complete.
 - c. Hydrant shall be furnished with a nozzle mounted four (4) foot tall flag painted red with a reflector decal.
 - d. The lower hydrant stem shall be one piece from the hydrant main valve to the traffic flange. If the hydrant base must be extended in the field due to unforeseen circumstances, the lower hydrant stem must be replaced to meet this requirement.
 - e. Hydrant shall be backfilled so the final grade is located at the bury line of the hydrant and traffic flange is located two (2) inches above final grade.
 - f. The final grading around the hydrant shall be level for a minimum distance of three (3) feet on all sides of the hydrant.
 - g. Hydrants shall be restrained to the water line main.
 7. Sewer/Water Line Alignment and Tracer Wire
 - a. Sewer lines and water lines shall have a minimum horizontal separation distance of 10 feet measured to the outside of the pipes. If crossings are required, the water line shall be laid over the sewer with a minimum vertical separation distance of 18 inches measured to the outside of the pipes. The water line joints must be kept as far away from the sewer line joints as possible by locating a full section of water line centered on the sanitary sewer. In addition, the first water line joint either side of the sanitary sewer shall be encased in six inches of concrete for two feet either side of the joint.
 - b. Concrete encasement must meet minimum concrete cure times before backfill of the trench and pressurization of pipe. Concrete encasement may be backfilled after 24 hours, however, no compaction will be allowed above the encasement for a minimum of 36 hours after concrete placement, unless longer times are required by the District. See Details G1 and G3.
 - c. If the separation requirements described above cannot be met, in addition, the sewer line shall be encased in six inches of concrete for a distance of 12 feet each side of the point of crossing.
 - d. An alternative to full encasement of the sewer line is to use C-900 PVC pressure pipe, Class 150, for the sewer pipe and encase the sewer pipe joints in six inches of concrete for two feet either side of the joint.
 - e. Service lines shall be laid to a uniform grade and straight alignment with

- use of fittings to obtain changes in alignment. Service line construction shall conform to the requirements of the latest edition of the Uniform Plumbing Code. Clean-outs shall be provided as required by the Code. Joints shall be securely made to prevent root penetration and eliminate infiltration. Joints between dissimilar materials shall be made with approved commercial adaptors designed for the purpose. Service lines eight inches or larger shall be installed with manholes.
- f. All waterline installations shall include tracer wire in accordance with District Tracer Wire Standards.
8. Water Line Connections
- a. Connections to the water main shall be done by a wet-tap method unless prior approval is obtained from the District to utilize an alternate method.
- b. Wet taps up to two (2)-inches, which are two (2) or more standard pipe sizes smaller than the water main line, shall be completed using a double strap tapping saddle. Double strap saddles shall be epoxy coated ductile iron or steel with stainless steel bands.
- c. Wet taps larger than two inches shall be completed with a ductile iron mechanical joint tapping sleeve equivalent to Mueller No. H-615 or H-616.
- d. All wet tap water line connectors must be reviewed and approved by the District prior to construction.
9. Thrust Blocks
- a. Cast-in-place thrust blocks are required at all bends and fittings which result in an unbalanced line thrust. See Detail W-6.
- b. Concrete shall have a minimum compressive strength of 3,000 psi, after 28 days, and must be completely batched before pouring into the thrust block forms.
- c. When placing the concrete, a bond breaker should be used between the pipe and concrete and care should be taken that the bolts, nuts, outlets or other fittings are not covered with concrete and made inaccessible. Blocks shall bear against undisturbed earth and shall be formed to provide symmetrical thrust distribution.
- d. **Thrust blocks may be backfilled after 24 hours, however no compaction will be allowed above the block for a minimum of 36 hours after placement, or as directed by the District. The concrete must set a minimum of 48 hours before the hydrostatic test, or until the full concrete compressive strength has been achieved. Block size shall be as shown on the plans.**
10. Excavation
- a. Excavations shall be made to the line and grade as shown on the approved drawings and conform to Detail G-2.
- b. The excavation shall extend beyond the proposed bottom and sides of the pipe to allow for placement and compaction of the required bedding material.
- c. Where materials are found to be unsuitable by the District, the unsuitable materials shall be removed and replaced with well graded gravel as

- d. required by the District in order to obtain a satisfactory foundation.
- d. Excavation shall be done in accordance with applicable regulations and in a manner to assure the safety of all persons and property. Consult the Utility Notification Center of Colorado at 800-922-1987 for locations of gas, telephone, water, sewer and other utilities before digging. A street cut permit is required by the Town of Winter Park.
- 11. Bedding
 - a. All pipe shall have six (6) inches of compacted bedding on the sides and bottom of the pipe and 12 inches of bedding on top of the pipe.
 - b. Table 1 shows the required bedding material gradation. See Detail G2.

**Table 1
Bedding Gradation**

Sieve Size	% by Weight Passing Square Mesh Sieves
1/2 inch	100
3/8 inch	85-100
No. 4	10-30
No. 8	0-10
No. 16	0-5
No. 200	0-1.5

- c. Care shall be taken that the bedding under the pipe haunches and up to the pipe springline is well compacted.
- d. If wet trench conditions are encountered or if required by the District, the trench shall be stabilized with stabilization material.
- e. Work must be inspected by the District prior to covering the pipe with bedding material and backfill.
- 12. Trench Backfill
 - a. Suitable materials from the excavation will be allowed to be used as backfill.
 - b. **Grand County Class C and fines are not allowed in the backfill.**
 - c. **Select or process clean fill, backfill, and embankment materials. Do not use wet, soft, or frozen material, asphalt and concrete chunks, cinders, ashes, refuse, vegetable or organic material, boulders, rock, or other deleterious material as backfill. In addition, no rocks larger than three inches are allowed within two feet of the pipe bedding zone.**
 - d. **Construction shall be done in accordance with Town of Winter Park standards and specifications for design and construction regarding opening and excavation of public places, including standards for replacement of fill materials and placement of course materials for roadways.**
- 13. Compaction
 - a. Compaction may be obtained by any method the contractor so desires (except water consolidation), as long as the backfill material is uniformly compacted throughout the depth of the trench to at least 95 percent of the

- maximum density obtainable using standard proctor. The minimum moisture content shall not deviate below the standard optimum by more than two percent. More stringent requirements may apply in roadways or other areas where permit requirements may control.
- b. If, in the judgment of the District, the trench shows signs of being improperly backfilled or if settlement occurs, the trenches will be re-opened to a depth required for proper compaction, re-filled and re-compacted, all in accordance with these specifications.
 - c. Compaction tests, taken by an independent commercial laboratory, shall be taken every 1.5 feet of depth and every 300 feet of trench length, or at the discretion of the District while construction is proceeding. The District shall pick the location and depths at which all compaction tests will be taken. Compaction tests shall be taken at depths below subgrade ranging from one (1) foot above the top of pipe bedding to one (1) foot below grade. The District shall be present when each test is taken and the results shall be forwarded to the District. The contractor shall bear the costs of all compaction tests.
15. Disposal Clean Up
- a. The disposal of unsuitable material and general construction waste shall be the responsibility of the contractor.
 - b. After the work is complete, the construction area shall be cleaned and revegetated.
16. General Warranty and Trench Maintenance
- a. For a period of one (1) year from the date of final approval of the project by the District, workmanship, materials and equipment incorporated in the project shall be guaranteed by the property owner to remain in normal working order and condition. If a repair is made due to warranty issues, the one-year warranty period is extended from the date the repair is completed.
 - b. For a period of one (1) year from the date of final approval of the project by the District, the contractor shall maintain and repair any trench settlement which may occur and shall make suitable repairs to any pipe, fitting, valve, valve box, pavement, sidewalks, or other structure which may be damaged as a result of backfill settlement as determined by the District on the District's engineer.
- E. Water Line Testing Procedures
1. Disinfection
 - a. Notify District personnel 48 hours in advance that new water lines need to be filled for disinfection. **Only District personnel are permitted to operate District valves or hydrants. Contractor shall not operate District valves to fill new lines.** District will note date and time lines filled and inform Contractor of retention schedule.
 - b. Newly installed pipe shall be disinfected in accordance with AWWA C-601, using the Tablet Method. A brief discussion of this method follows. With the Tablet Method of disinfection, the pipe must be kept clean and dry during construction.

- c. During construction, 5-g calcium hypochlorite tablets are placed in each section of pipe, fire hydrant, and other appurtenance. The tablets must be attached inside the pipe at the top with an adhesive such as Permatex No. 1, or equal. Reference AWWA C-601 for the number of required tablets.
 - d. After the pipe has been completely installed and tablets are in place, the pipe should be filled with water slowly (1 fps maximum velocity) so the tablets are not washed away. Once filled, the chlorinated water must remain in the pipe for at least 24 hours. If the water temperature is less than 41 degrees F, the chlorinated water must remain in the pipe for 48 hours. The chlorine concentration in the pipe must be 25 mg/l after 24 hours.
2. Chlorine residual sampling will be performed before flushing by the contractor under the supervision of District personnel. Chlorine residual analysis will be performed by District personnel. Once the application retention period has been met, the heavily chlorinated water must be flushed from the pipe until the chlorine concentration in the pipe is no higher than is normal for the system. Heavily chlorinated water must be de-chlorinated with Sodium Thiosulfite (Na₂S₂O₃) or other approved method. See the following section on Flushing for more information.
3. Flushing
- a. Notify District personnel 48 hours in advance that flushing operations are desired. **Only District personnel are permitted to operate District valves or hydrants. Contractor shall not operate District valves to flush new lines.** Flushing operations shall be observed by District personnel.
 - b. New pipe must be flushed prior to putting it in service. Preferably it should be done before conducting the pressure test. Flushing velocities should be high enough to remove all foreign materials from the pipe. The table below shows required flushing rates for various pipe diameters.
 - c. Contractor shall obtain necessary discharge permits form CDPHE prior to flushing. The contractor is cautioned that the discharge of water during flushing operations shall not create erosion channels or damage private or municipal property. The contractor is advised that the CDPHE will not permit chlorinated water to be discharged to a stream; and such chlorinated water may **NOT** be discharged to the sanitary sewer due to the impact on the wastewater treatment plant.
 - d. See Table 3 for pipe flushing rates.

**Table 3
Pipe Flushing Rates**

Pipe Diameter (inches)	Flow Required for Flushing (2.5 fps) (gpm)
6	220
8	390
10	610
12	880

- e. At the discretion of District personnel, the contractor may be required to provide chlorine residual samples from the flushed lines. The purpose of said sample is to verify that the heavily chlorinated water for disinfection has been removed.
4. Pressure/Leakage Test
- a. Notify District personnel 48 hours in advance of when Contractor desires to perform pressure leakage test. Testing shall be observed by District personnel. Pressure testing can be performed immediately after flushing if so desired by the contractor.
 - b. Before new pipe lines are put in service, they must pass a hydrostatic pressure test and a leakage test, done in accordance with AWWA C-600. Equipment, labor and materials required to complete the pressure/leakage test shall be approved by the District and furnished by the contractor. Testing shall be done under the supervision of the District at the expense of the contractor. Contractor shall provide the District with pipe size, length, fittings, and elevations so District personnel can determine test pressure and allowable leakage. It may be required to test pipes in sections to meet test requirements of AWWA C-600 and pressure in the system.
 - c. The test equipment shall include the following:
 - 1. Maximum meter size of 5/8-inch with 0.10 gallon increments,
 - 2. Three to four-inch pressure gauge with increments of one (1) psi,
 - 3. Pump to pressurize water main, with pressure relief valve, each of which is adjustable and sized to the applicable test pressure and low flow rate to properly perform the test.
 - d. Pipe shall be subject to a test pressure of at least 1.5 times the working pressure at the point of testing. The test pressure at the highest point in any section shall not be less than 1.25 times the working pressure at that point. The pressure will last for two hours, and the pressure shall not vary +/- five (5) psi. Under no circumstances shall the test pressure be in excess of the design pressure for the pipe or thrust restraint. The contractor shall review the sequence and procedure for testing new pipe with the District prior to testing.
 - e. The leakage test shall be done at the same time as the pressure test. The actual allowable leakage and test pressure will be determined by the District in accordance with AWWA C-600. Table 4 shows the general allowable leakage rates for reference.

Table 4
Allowable Leakage per 1,000 Feet of Pipe (gph) *

Test Pressure (psi)	Pipe Diameter (inches)			
	6	8	10	12
150	0.55	0.74	0.92	1.10
200	0.64	0.85	1.06	1.28
250	0.71	0.95	1.19	1.42
300	0.78	1.04	1.30	1.56
350	0.84	1.12	1.40	1.69
400	0.90	1.20	1.50	1.80

*Based on AWWA Standards Section C-600.

*For pipe with 18-ft nominal lengths. To obtain the recommended allowable leakage for pipe with 20-ft nominal lengths, multiply the leakage calculated from the table by 0.9.

5. Bacteriological Test

- a. Notify District personnel 48 hours in advance of when contractor desires to take samples for bacteriological test.
- b. New water line must pass tests for bacteriological contamination as required by CDPHE. All sampling and testing is the responsibility of the contractor. The bacteriological sampling shall occur after pressure testing and flushing. A minimum of two (2) samples will be analyzed. All samples will be collected in duplicate; two (2) samples from each test location. If the samples show no bacteriological growth and are free from excessive turbidity, the District will approve the bacteriological test.
- c. If samples do not warrant approval of the water lines, then the lines must be re-flushed. If samples do not warrant approval after re-flushing, re-chlorination shall be required.
- d. Bacteriological sampling will be performed by the contractor under supervision of District personnel. The contractor will be responsible for obtaining bacteriological testing by submitting the samples to the CDPHE central laboratory in Denver, or by making arrangements with another state-certified approved lab. The contractor is advised that no bacteriological sampling can be performed on Friday, since neither laboratory works on weekends and the sample must be analyzed within 24 hours. Cost of the collection and lab tests shall be the responsibility of the contractor.

Section IV Water Service Specifications**A. General**

These Specifications provide requirements for water service design and construction. No excavations for water or sewer construction are permitted between October 15 and May 1. These dates may be subject to change by the District due to the prevailing weather conditions.

B. Related Requirements

District Standard Details for Water Service Lines are located in the Appendix of these Regulations.

C. Materials and Construction**1. Water Service Line Installation (outside)**

- a. Water service shall be constructed as shown on the drawings and in accordance with District standards, which can be obtained by contacting District personnel.
- b. All materials shall be new and undamaged.
- c. Minimum depth of bury shall be nine (9) feet.
- d. The water service line corporation stop shall be installed on the water main/distribution system pipe per District Standards. The location of the corporation stop shall be coordinated and approved by the District prior to construction.
- e. The curb stop box shall be installed vertically exactly over the center of the valve. Location of the curb box on the property shall be coordinated and approved by the District prior to construction.
- f. Any variance from this will be cause to reset the box. All work must be inspected and approved by the District before backfilling.

2. Water Service Line Installation (inside)

- a. All materials shall be new and undamaged.
- b. The inside water service installation consisting of the isolation valve, strainer, pressure reducing valve (PRV), yoke and meter, backflow preventor shall be installed as directed by District personnel. Each installation will be somewhat different but each must conform to the requirements shown. No buried soldered fittings are permitted. Any questions or conflicts should be brought to the attention of the District.
- c. It is the property owner's responsibility that all parts of the water service are protected from any potential damage, including freezing.
- d. Work must be inspected and approved by the District before the service will be turned on.

3. Specified Materials

- a. The District will allow only District specified materials to be used in construction in order to assure quality control and to standardize components used in the system. Table 1 shows a list of the major components that are approved by the District for water service construction. The District will review other components for "or equal" consideration.

Table 1
Specified Materials

Item	Specifications
Service Clamp (up to 2-inch tap size)	Epoxy-coated ductile iron with stainless steel double strap, or bronze body with bronze double strap; Mueller DR2S C-C thread; 500 psi rated; direct tapping not permitted
Corporation Stop	Mueller No. B-25000
Curb Stop	Mueller No. B-25204
Curb Box (1-inch ID riser with foot piece, arch base, 2-piece lid, stationery rod)	Mueller H-10334 (with pinned extension to extend within 2-feet of box top)
Meter/Remote Readout	Furnished by District
Meter Yoke	Furnished by District
Pressure Reducing Valve w/Strainer	Furnished by District
Backflow Preventor	Furnished by District
Underground Service Line	Type K, copper
Underground Service Line Coupling	Pipe up to 1-inch may be joined with flared coupling or compression coupling with integral mechanical restraint. Pipe larger than 1-inch shall be joined with integral mechanical restraint. Flare coupling – Mueller No. H-15400. Compression coupling – Mueller No. H-15403.

4. Sewer/Water Line Alignment
 - a. Sewer lines and water lines shall have a minimum horizontal separation distance of 10 feet measured to the outside of the pipes. If crossings are required, the water line shall be laid over the sewer with a minimum vertical separation distance of 18 inches measured to the outside of the pipes. The water line joints must be kept as far away from the sewer line joints as possible by locating a full section of water line centered on the sanitary sewer. In addition, the first water line joint either side of the sanitary sewer shall be encased in six inches of concrete for two feet either side of the joint.
 - b. Concrete encasement must meet minimum concrete cure times before backfill of the trench and pressurization of pipe. Concrete encasement may be backfilled after 24 hours, however, no compaction will be allowed above the encasement for a minimum of 36 hours after concrete placement, unless longer times are required by the District. See Details G1 and G3.
 - c. If the separation requirements described above cannot be met, in addition, the sewer line shall be encased in six inches of concrete for a distance of 12 feet each side of the point of crossing.
 - d. An alternative to full encasement of the sewer line is to use C-900 PVC

TECHNICAL SECTIONS

#

- pressure pipe, Class 150, for the sewer pipe and encase the sewer pipe joints in six inches of concrete for two feet either side of the joint.
- e. Water Service lines shall be laid to a uniform grade and straight alignment with use of fittings to obtain changes in alignment. Service line construction shall conform to the requirements of the latest edition of the Uniform Plumbing Code.
5. Connection to Main
- a. Services shall be connected to the main using a double strap service clamp and corporation stop. Direct tapping where the curb stop is threaded to the water main is not permitted. Connections shall be “wet” connections. Any conflicts should be brought to the attention of the District.
6. Excavation
- a. Excavations shall be made to the line and grade as shown on the approved drawings and conform to Detail G-2.
 - b. The excavation shall extend beyond the proposed bottom and sides of the pipe to allow for placement and compaction of the required bedding material.
 - c. Where materials are found to unsuitable by the District, the unsuitable materials shall be removed and replaced with well graded gravel as required by the District in order to obtain a satisfactory foundation.
 - d. Excavation shall be done in accordance with applicable regulations and in a manner to assure the safety of all persons and property. Consult the Utility Notification Center of Colorado at 800-922-1987 for locations of gas, telephone, water, sewer and other utilities before digging. A street cut permit is required by the Town of Winter Park.
7. Bedding
- a. All pipe shall have six (6) inches of compacted bedding on the sides and bottom of the pipe and 12 inches of bedding on top of the pipe.
 - b. Table 2 shows the required bedding material gradation. See Detail G2.

Table 2
Bedding Gradation

Sieve Size	% by Weight Passing Square Mesh Sieves
1/2 inch	100
3/8 inch	85-100
No. 4	10-30
No. 8	0-10
No. 16	0-5
No. 200	0-1.5

- c. Care shall be taken that the bedding under the pipe haunches and up to the pipe springline is well compacted.
- d. If wet trench conditions are encountered or if required by the District, the trench shall be stabilized with stabilization material.
- e. Work must be inspected by the District prior to covering the pipe with

- bedding material and backfill.
8. Trench Backfill
 - a. Suitable materials from the excavation will be allowed to be used as backfill material.
 - b. Grand County Class C and or materials with fines exceeding the material gradation requirements are not allowed in the backfill.**
 - c. Select or process clean fill, backfill, and embankment materials. Do not use wet soft, or frozen material, asphalt and concrete chunks, cinders, ashes, refuse, vegetable or organic material, boulders, rock, or other deleterious material as backfill. In addition, no rocks larger than 12 inches are allowed anywhere in the backfill, and no rocks larger than six inches are allowed within two feet of the pipe bedding zone.**
 - d. Construction shall be done in accordance with Town of Winter Park standards and specifications for design and construction regarding opening and excavation in public places, including standards for replacement of fill materials and placement of course materials for roadways.**
 9. Compaction
 - a. Compaction shall be obtained by the contractor using industry standard accepted methods (except water consolidation), as long as the backfill material is uniformly compacted throughout the depth of the trench to at least 95 percent of the maximum density obtainable using standard proctor. The minimum moisture content shall not deviate below the standard optimum by more than two percent. More stringent requirements may apply in roadways or other areas where permit requirements may control.
 - b. If, in the judgment of the District, the trench shows signs of being improperly backfilled or if settlement occurs, the trenches will be re-opened to a depth required for proper compaction, re-filled and re-compacted, all in accordance with these specifications.
 - c. Compaction tests, taken by an independent commercial laboratory, shall be taken every 1.5 feet of depth and every 300 feet of trench length, or at the discretion of the District while construction is proceeding. The District shall pick the location and depths at which all compaction tests will be taken. Compaction tests shall be taken at depths below subgrade ranging from one foot above the top of pipe bedding to one foot below grade. The District shall be present when each test is taken and the results shall be forwarded to the District. The contractor shall bear the costs of all compaction tests.
 10. Disposal/Clean Up#
 - a. The disposal of unsuitable material and general construction waste shall be the responsibility of the contractor.
 - b. After the work is complete, the construction area shall be cleaned and revegetated.
 11. Abandonment of Water Service Line or Tap

- a. Procedures to abandon an unused water service tap include removal of the corporation stop and plugging the service saddle with an approved plug.
 - b. Under no circumstances shall a water service line be abandoned without removing the connection of the copper service line from the water main.
 - c. Water taps that have been pre-installed that are no longer to be used must be properly abandoned at the time the lot is developed and prior to activation of the service to the property.
 - d. Water taps that are pre-installed and subsequently not required shall be properly abandoned prior to activation of the service to the property.
12. General Warranty and Trench Maintenance
- a. For a period of one (1) year from the date of final approval of the project by the District; workmanship, materials and equipment incorporated in the project shall be guaranteed by the property owner to remain in normal working order and condition. If a repair is made due to warranty issues, the one-year warranty period is extended to one year from the date the repair is completed. During the one (1) year period from the date of final approval of the project by the District, the owner shall maintain and repair any trench settlement which may occur and shall make suitable repairs to any pipe, fitting, valve, valve box, pavement, sidewalks, or other structure which is or may be damaged as a result of backfill settlement as determined by the District.
- D. Water Service Line Testing Procedures
1. Leak Test
 - a. A water service line leakage test is required. The District will advise the contractor of the appropriate procedures. The cost of leak testing is the responsibility of the Contractor.

Section V Irrigation Specifications**A. General**

These Specifications provide requirements for water service design and construction. No excavations for water or sewer construction are permitted between October 15 and May 1. These dates may be subject to change by the District due to the prevailing weather conditions.

B. Related Requirements

District standard details are located in the Appendix of these Regulations.

C. Irrigation - The District encourages water conservation and requests close monitoring of irrigation to avoid depleting water availability for domestic use. Water will be provided for irrigation purposes as District water capacity is available. The water supplied for irrigating is treated water. Owners must be conscientious when irrigating as great quantities of water can be used in short time periods. Irrigation water does not return to the District's system as waste-water, therefore is not returned to the river; it is considered 'consumptive' use. Natural landscaping is encouraged, i.e. landscaping which requires very little watering. There are specific types of grass and plants that grow better in high altitude and require less water, rock and/or bark can be used for ground cover.

1. The water tap for a single family detached home includes a water allowance for landscape irrigation for the area directly around the residence that is owned solely by that resident. The irrigation allowance is set to provide a reasonable level of irrigation capacity while at the same time limiting the impact of irrigation use on the water system. This impact is controlled by limiting the rate of flow and volume of water use, and by limiting the area of landscaping that may be irrigated. The District may impose additional irrigation restrictions as necessary to safely operate the water system and provide adequate capacity for domestic uses. The landscaping irrigation allowance is defined according to the type of development, as shown in the following table:

**Table 1
Irrigation Allowance**

Description	Allowable Area of Irrigation (square feet)	Total Max. Rate of Irrigation Water Use (gallons/minute)	Total Max. Volume of Irrigation Water Use Per Month (gallons)
Detached Single Family Residence Landscaping	4,000	8	7,500
Multi-Family Development	1,500	8	2,800
-Building Landscaping, per 4 unit building equivalent	2,000	8	3,700
-Common Area Landscaping			
Commercial Development	1,500	8	2,800
-Building Landscaping, per 4 unit building equivalent	2,000	8	3,700
-Common Area Landscaping			

Note: Irrigation volume is based on a maximum of 3-inches of irrigation per month.

2. Landscaping irrigation is permitted as described in this section, upon payment of building tap fees in accordance with District policy.
3. Irrigation of Common Area landscaping prior to payment of building tap fees will require payment of tap fees for landscape irrigation. Irrigation water taps may later be re-assigned to building tap fees within the development but shall not be used to irrigate common areas. The required tap fees will be determined by the District.
4. Building Landscaping is defined as landscaping immediately adjacent to the building and may be metered through the building water meter.
5. Common Area Landscaping is defined as the landscaping in common areas intended for use by the public and would include areas such as entrance signage. Common Areas must be irrigated through a separate service line and meter dedicated for that purpose. Irrigation meter installation shall conform to Detail I-1.
6. If an owner/developer operates, or is considering installation of, a built-in sprinkler system for either an existing or new building, the owner/developer must schedule a meeting with District personnel to review landscaping plans. District personnel can then provide information on allowable rates of irrigation water use, sprinkler zoning, flow restrictors, and possibly alternate watering days with other irrigation users in the District.
7. Irrigation water must be metered and is billed as regular water use.
8. The District reserves the right to schedule or ban irrigation use within District boundaries. If drought conditions develop, use of water for irrigation would be banned and users would be notified to suspend all irrigation during the drought period.

Section VI Sanitary Sewer Main Specifications

A. General

These Specifications provide requirements for sanitary sewer main design and construction. No excavations for water or sewer construction are permitted between October 15 and May 1. These dates may be subject to change by the district due to the prevailing weather conditions.

B. Related Requirements

District standard details are located in the Appendix of these Regulations.

C. Design Criteria

1. Design Flow/Pipe Sizing

- a. The design flow, for full-pipe condition, for sanitary sewers shall be the sum of all contributory flows to the sewer (as calculated from the District ESFU Assessment Schedule-Exhibit A), multiplied by a peaking factor of four (4).
- b. Sewers shall be designed to maintain minimum velocities of 2 feet per second as calculated by Mannings equation, with a roughness coefficient of 0.13 and shall have minimum slopes as can be seen in Table 1.

**Table 1
Minimum Pipe Slope**

Sewer Pipe Diameter (inches)	Minimum Slope (percent)
8	0.40
10	0.28
12	0.22
15	0.16
18	0.12
21	0.10
24	0.08

- c. The minimum collector sewer size shall be eight inches. Design work is subject to review by the District.

2. System Layout

- a. Sanitary sewers should be located on the south or west side of a dedicated street. If the sewer cannot be installed in a dedicated street, it may be installed in easements and rights-of-way granted on forms satisfactory to the District. Any easements or rights-of-way shall have a minimum width of 20 feet for one utility and 30 feet for two utilities. Easement width shall be at least twice the depth to the deepest utility.
- b. Sewer lines shall be laid in straight lines using a laser for alignment and shall have manholes at all changes in grade, size, alignment, or intersections. Manholes shall also be spaced at distances not greater than 400 feet. Drop manholes are not acceptable design practice for the District system unless prior written approval is received from the District. See Details S-2. Minimum depth of cover for sewer pipe is six feet. The

maximum depth of the sewer is 12 feet unless prior written approval is received from the District. All work must be inspected and approved by District personnel prior to backfilling.

D. Materials and Construction

1. Sewer Line Installation

- a. Materials, including pipe, fittings, valves, and other sewer line appurtenances shall be new and shall be installed in accordance with the manufacturers' instructions. District personnel must inspect and approve all work outlined in this Section prior to backfilling. During installation, care shall be taken to prevent foreign material from entering the pipe. These preventive measures shall include plugging pipe openings with mechanical pipe plugs whenever pipe-laying is not in progress, and at the end of each day. See Detail S-1.

2. Sewer Pipe

- a. Sanitary sewer pipe and fittings shall be PVC and shall meet strength minimum of SDR-35 and all requirements of ASTM D-3034 or latest revision.
- b. Pipe shall be installed as recommended by the manufacturer. Joints shall be gasketed bell and spigot. No glue joints are permitted.

3. Manholes

- a. All manhole bases shall be precast.
- b. Manhole riser sections, eccentric cones and precast bases shall meet the requirements of ASTM C-478. Precast bases shall incorporate boot-type seal with the sewer pipe. The space between the boot and the pipe shall be grouted after backfilling of the manhole is complete. Manhole bases shall be brought to grade with a minimum of 6-inches of bedding material. Manhole bench must be poured after manhole base and pipe are installed. See Detail S-3.
- c. If conditions do not permit the use of precast manhole bases, cast-in-place manhole bases may be used only with prior District approval. If cast-in-place bases are used, base shall be 18 inches minimum thickness and shall have an O-ring gasket seal with the pipe. Cast-in-place manhole bases shall be formed with manhole ring form to match manhole riser section. All channels shall be smooth. Benches shall be above pipe-crown and shall slope at no greater than 1-inch per foot.
- d. Manholes shall be furnished with factory applied bituminous coating throughout the exterior surface of the manhole.
- e. Manhole joints shall be sealed water tight with Ram-Nek mastic compound and all manhole joints shall be grouted on the inside of the manhole to form a smooth interior wall. Exterior manhole joints shall be water-proofed with bituminous coating and bituthane wrap. Bituthane wrap shall extend a minimum of 6-inches beyond the edge of the joint and shall lap 6-inches at the ends.
- f. Manholes should be 48 inch I.D. unless directed otherwise by the District.
- g. The manhole ring and cover shall be cast iron equivalent to the 400 pound "Denver Heavy." Cover shall be 24-inches in diameter and shall have

- “SEWER” cast into it. See Detail S-4.
- h. The manhole rim shall be brought to grade with concrete rings. The height of this ‘stack’ of rings shall be between 4-inches and 12-inches to allow for future grade adjustment.
 - i. Manhole steps shall be plastic coated steel and shall be spaced 16 inches on center. Steps shall be cast into concrete or installed with epoxy.
 - j. Connections to existing manholes shall be made by core hole drilling through the existing manhole and bench in such a manner that the finished work will conform as nearly as practical to the requirements of new construction. Any other type of construction must be approved by the District prior to initiation of any work.
4. Sewer/Water Line Alignment and Tracer Wire
- a. Sewer lines and water lines shall have a minimum horizontal separation distance of 10 feet measured to the outside of the pipes. If crossings are required, the water line shall be laid over the sewer with a minimum vertical separation distance of 18 inches measured to the outside of the pipes. The water line joints must be kept as far away from the sewer line joints as possible by locating a full section of water line centered on the sanitary sewer. In addition, the first water line joint either side of the sanitary sewer shall be encased in six inches of concrete for two feet either side of the joint.
 - b. Concrete encasement must meet minimum concrete cure times before backfill of the trench and pressurization of pipe. Concrete encasement may be backfilled after 24 hours, however, no compaction will be allowed above the encasement for a minimum of 36 hours after concrete placement, unless longer times are required by the District. See Details G-1 and G-3.
 - c. If the separation requirements described above cannot be met, in addition, the sewer line shall be encased in six inches of concrete for a distance of 12 feet each side of the point of crossing.
 - d. An alternative to full encasement of the sewer line is to use C-900 PVC pressure pipe, Class 150, for the sewer pipe and encase the sewer pipe joints in six inches of concrete for two feet either side of the joint.
 - e. Service lines shall be laid to a uniform grade and straight alignment with use of fittings to obtain changes in alignment. Service line construction shall conform to the requirements of the latest edition of the Uniform Plumbing Code. Clean-outs shall be provided as required by the Code. Joints shall be securely made to prevent root penetration and eliminate infiltration. Joints between dissimilar materials shall be made with approved commercial adaptors designed for the purpose. Service lines eight inches or larger shall be installed with manholes.
 - f. All sanitary sewer pipe and sewer lateral installations shall include tracer wire in accordance with District Tracer Wire Standards.
5. Excavation
- a. Excavations shall be made to the line and grade as shown on the approved drawings and conform to Detail G-2.

- b. The excavation shall extend beyond the proposed bottom and sides of the pipe to allow for placement and compaction of the required bedding material.
 - c. Where materials are found to be unsuitable by the District, the unsuitable materials shall be removed and replaced with well graded gravel as required by the District in order to obtain a satisfactory foundation.
 - d. Excavation shall be done in accordance with applicable regulations and in a manner to assure the safety of all persons and property. Consult the Utility Notification Center of Colorado at 800-922-1987 for locations of gas, telephone, water, sewer and other utilities before digging. A street cut permit is required by the Town of Winter Park.
6. Bedding
- a. All pipe shall have six (6) inches of compacted bedding on the sides and bottom of the pipe and 12 inches of bedding on top of the pipe.
 - b. Table 2 shows the required bedding material gradation.

**Table 2
Bedding Gradation**

Sieve Size	% by Weight Passing Square Mesh Sieves
1/2 inch	100
3/8 inch	85-100
No. 4	10-30
No. 8	0-10
No. 16	0-5
No. 200	0-1.5

- c. Care shall be taken that the bedding under the pipe haunches and up to the pipe springline is well compacted.
 - d. If wet trench conditions are encountered or if required by the District, the trench shall be stabilized with stabilization material.
 - e. Work must be inspected by the District prior to covering the pipe with bedding material and backfill.
7. Trench Backfill
- a. Suitable materials from the excavation will be allowed to be used as backfill.
 - b. **Grand County Class C and or materials with fines exceeding the material gradation requirements are not allowed in the backfill.**
 - c. **Select or process clean fill, backfill, and embankment materials. Do not use wet, soft, or frozen material, asphalt and concrete chunks, cinders, ashes, refuse, vegetable or organic material, boulders, rock, or other deleterious material as backfill. In addition, no rocks larger than three inches are allowed within two feet of the pipe bedding zone.**
 - d. **Construction shall be done in accordance with Town of Winter Park standards and specifications for design and construction regarding opening and excavation of public places, including standards for**

replacement of fill materials and placement of course materials for roadways.

8. **Compaction**
 - a. Compaction may be obtained by any method the contractor so desires (except water consolidation), as long as the backfill material is uniformly compacted throughout the depth of the trench to at least 95 percent of the maximum density obtainable using standard proctor. The minimum moisture content shall not deviate below the standard optimum by more than two percent. More stringent requirements may apply in roadways or other areas where permit requirements may control.
 - b. If, in the judgment of the District, the trench shows signs of being improperly backfilled or if settlement occurs, the trenches will be re-opened to a depth required for proper compaction, re-filled and re-compacted, all in accordance with these specifications.
 - c. Compaction tests, taken by an independent commercial laboratory, shall be taken every 1.5 feet of depth and every 300 feet of trench length, or at the discretion of the District while construction is proceeding. The District shall pick the location and depths at which all compaction tests will be taken. Compaction tests shall be taken at depths below subgrade ranging from one foot above the top of pipe bedding to one foot below grade. The District shall be present when each test is taken and the results shall be forwarded to the District. The contractor shall bear the costs of all compaction tests.
9. **Disposal Clean Up**
 - a. The disposal of unsuitable material and general construction waste shall be the responsibility of the contractor.
 - b. After the work is complete, the construction area shall be cleaned and revegetated.
10. **General Warranty and Trench Maintenance**
 - a. For a period of one (1) year from the date of final approval of the project by the District, workmanship, materials and equipment incorporated in the project shall be guaranteed by the property owner to remain in normal working order and condition. If a repair is made due to warranty issues, the one-year warranty period is extended from the date the repair is completed.
 - b. For a period of one (1) year from the date of final approval of the Project by the District, the contractor shall maintain and repair any trench settlement which may occur and shall make suitable repairs to any pipe, fitting, valve, valve box, pavement, sidewalks, or other structure which may be damaged as a result of backfill settlement as determined by the District or the District's engineer.
- E. **Sewer Line Testing Procedures**
 1. New sanitary sewer line construction shall be cleaned by jetting, video inspected, and tested for tightness by the vacuum testing, per ASTM C-1214. A DVD of the inspection shall be provided to the District within seven (7) days of the date of video inspection.

TECHNICAL SECTIONS

2. Cleaning and video inspections shall be performed by a qualified and experienced contractor approved by the District.
3. Sanitary Sewer Vacuum Testing
 - a. Use extreme care and follow safety precautions during testing operations. Keep personnel out of and away from manholes during testing.
 - b. Where practical, clean pipe prior to testing and wet the pipe surface. Isolate test segment as necessary, including closing service connections.
 - c. Test Procedure
 - Determine test time for size of pipe being tested using following Minimum Test Time Table.
 - Test time is time required for vacuum to drop from 7 to 5 inches of mercury.
 - Minimum Test Time Table.

Nominal Pipe (Inches)	T(time) Minutes/100ft. of pipe	Nominal Pipe (inches)	T(time) Minutes/100 ft. of pipe
4	0.3	21	3.0
6	0.7	24	3.6
8	1.2	27	4.2
10	1.5	30	4.8
12	1.8	33	5.4
15	2.1	36	6.0
18	2.4		

- Use a vacuum pump with capacity to evacuate sewer test section in time equal or less than that shown in Minimum Test Time Table for size of pipe being tested.
 - Evacuate air until internal air pressure of the sewer line is lowered to approximately eight (8) inches of mercury. Allow the air pressure to stabilize.
 - When air pressure is stabilized near the starting test vacuum of seven (7) inches of mercury, commence test by allowing gage pressure to drop to seven (7) inches of mercury, then commence time recording. Record drop in vacuum for test period.
 - If drop in vacuum is two (2) inches of mercury or less during test period, test will be considered successfully passed.
 - If drop in vacuum is greater than two (2) inches of mercury during test period, inspect, evaluate, repair and retest.
4. An infiltration test and/or deflection test may be required by the District. All visible or detectable leaks shall be repaired under any circumstances.
 5. Testing will be done by the contractor under supervision of the District at the contractor's expense. All materials and equipment required for testing shall be furnished by the contractor. The contractor shall bear the cost of replacing any pipe or work not meeting the requirements of the testing or plans and specifications.

Section VII Sanitary Sewer Service Line Specifications

A. General

These Specifications provide requirements for sanitary sewer service line design and construction. No excavations for water or sewer construction are permitted between October 15 and May 1. These dates may be subject to change by the District due to the prevailing weather conditions.

B. Related Requirements

District standard details are located in the Appendix of these Regulations.

C. Materials and Construction

1. Sewer Pipe Installation

- a. Sewer service shall be constructed as shown on the drawings and in accordance with District standards, which can be obtained by contacting District personnel.
- b. All materials shall be new and undamaged. Sanitary sewer service pipe and fittings shall be PVC-SDR 35 meeting the requirements of ASTM D-3034 or latest revision.
- c. If conditions require the use of ductile iron pipe, the ductile iron shall be manufactured in accordance with AWWA C-151.
- d. All pipe shall have push-on gasket-type joints. Glue joints are not permitted.

2. Location/Slope

- a. The proposed location of the sewer lateral must be approved by the District before construction begins.
- b. Sewer laterals, if possible, should be located five (5) feet to the low side of the lot from the centerline. Sewer lines shall not be within five (5) feet of the property line. Additional location requirements can be seen in the following section on Sewer/Water Line Alignment.
- c. Sewer service laterals shall have a minimum pipe cover depth of 6 feet measured from the final grade.
- d. The minimum service line diameters and slopes can be seen in Table 1.

**Table 1
Service Line Diameters and Slopes**

Type of Service	Diameter (inches)	Slope (inch/foot)
Single Family	4	1/4
Duplex	6	1/16
Apartment/Condominium	6 or 8	1/16

3. Sewer/Water Line Alignment

- a. Sewer lines and water lines shall have a minimum horizontal separation distance of 10 feet measured to the outside of the pipes. If crossings are required, the water line shall be laid over the sewer with a minimum vertical separation distance of 18 inches measured to the outside of the pipes. The water line joints must be kept as far away from the sewer line

- joints as possible by locating a full section of water line centered on the sanitary sewer. In addition, the first water line joint either side of the sanitary sewer shall be encased in six inches of concrete for two (2) feet either side of the joint.
- b. Concrete encasement must meet minimum concrete cure times before backfill of the trench and pressurization of pipe. Concrete encasement may be backfilled after 24 hours, however, no compaction will be allowed above the encasement for a minimum of 36 hours after concrete placement, unless longer times are required by the District. See Details G-1 and G-3.
 - c. If the separation requirements described above cannot be met, in addition, the sewer line shall be encased in six inches of concrete for a distance of 12 feet each side of the point of crossing.
 - d. An alternative to full encasement of the sewer line is to use C-900 PVC pressure pipe, Class 150, for the sewer pipe and encase the sewer pipe joints in six inches of concrete for two feet either side of the joint.
 - e. Service lines shall be laid to a uniform grade and straight alignment with use of fittings to obtain changes in alignment. Service line construction shall conform to the requirements of the latest edition of the Uniform Plumbing Code. Clean-outs shall be provided as required by the Code. Joints shall be securely made to prevent root penetration and eliminate infiltration. Joints between dissimilar materials shall be made with approved commercial adaptors designed for the purpose. Service lines eight inches or larger shall be installed with manholes.
4. Connection to Main
- a. Sewer laterals shall be connected to an existing main with a double stainless steel band plastic saddle located at a 45-degree angle above the pipe centerline. No part of the sewer lateral may project within the sewer main. See Detail S-1.
 - b. The pipe opening shall be made by a mechanical tapping device unless otherwise approved by the District. The pipe coupon cut out by the tapping operations shall be removed from the sewer to prevent obstruction of flow, and preserved for District inspection. If coupling is required on the sewer lateral, it shall conform to Detail S-1.
 - c. If the sewer pipe should break during digging or tapping operations, it must be replaced, not patched or encased, so that the line will not leak and will be free from obstructions and the danger of flow stoppage. The person or contractor making the service connection shall be responsible for and bear the expense of replacing broken pipe. The repair shall be inspected and approved by the District prior to backfilling.
 - d. The person or contractor making the service connection shall measure the distance from the nearest sewer manhole to the point of connection into the sewer main and provide a drawing to the District showing the service line location.

- e. The owner of the property served by the sewer service connection shall be responsible for all costs involved in the installation and maintenance of the service line.
 - f. The District shall be notified not less than 24 hours before excavation for a sewer tap for a service line extension is started, and construction shall be inspected and approved by an authorized representative of the District before backfilling.
 - g. The District reserves the right to perform tests or make observations to determine the infiltration rate in service lines and main extensions. In the event that infiltration exceeds 250 gallons per day/inch of pipe or diameter/mile of pipe, the District may require the owner to repair the line to the satisfaction of the District. Regardless of the above, all visible or detectable leaks shall be repaired under any circumstances.
 - h. No downspouts, subsurface drainage or storm water drainage shall be discharged into the sanitary sewer system.
5. Excavation
- a. Excavations shall be made to the line and grade as shown on the approved drawings and conform to Detail G-2
 - b. The excavation shall extend beyond the proposed bottom and sides of the pipe to allow for placement and compaction of the required bedding material.
 - c. Where materials are found to be unsuitable by the District, the unsuitable materials shall be removed and replaced with well graded gravel as required by the District in order to obtain a satisfactory foundation.
 - d. Excavation shall be done in accordance with applicable regulations and in a manner to assure the safety of all persons and property. Consult the Utility Notification Center of Colorado at 800-922-1987 for locations of gas, telephone, water, sewer and other utilities before digging. A street cut permit is required by the Town of Winter Park.
6. Bedding
- a. All pipe shall have six (6) inches of compacted bedding on the sides and bottom of the pipe and 12 inches of bedding on top of the pipe.
 - b. Table 2 shows the required bedding material gradation.

Table 2
Bedding Gradation

Sieve Size	% by Weight Passing Square Mesh Sieves
1/2 inch	100
3/8 inch	85-100
No. 4	10-30
No. 8	0-10
No. 16	0-5
No. 200	0-1.5

- c. Care shall be taken that the bedding under the pipe haunches and up to the pipe springline is well compacted.

- d. If wet trench conditions are encountered or if required by the District, the trench shall be stabilized with stabilization material.
 - e. Work must be inspected by the District prior to covering the pipe with bedding material and backfill.
7. Trench Backfill
- a. Suitable materials from the excavation will be allowed to be used as backfill material.
 - b. Grand County Class C and or materials with fines exceeding the material gradation requirements are not allowed in the backfill.**
 - c. Select or process clean fill, backfill, and embankment materials. Do not use wet, soft, or frozen material, asphalt and concrete chunks, cinders, ashes, refuse, vegetable or organic material, boulders, rock, or other deleterious material as backfill. In addition, no rocks larger than three inches are allowed within two feet of the pipe bedding zone.**
 - d. Construction shall be done in accordance with Town of Winter Park standards and specifications for design and construction regarding opening and excavation of public places, including standards for replacement of fill materials and placement of course materials for roadways.**
8. Compaction
- a. Compaction may be obtained by any method the contractor so desires (except water consolidation), as long as the backfill material is uniformly compacted throughout the depth of the trench to at least 95 percent of the maximum density obtainable using standard proctor. The minimum moisture content shall not deviate below the standard optimum by more than two percent. More stringent requirements may apply in roadways or other areas where permit requirements may control.
 - b. If, in the judgment of the District, the trench shows signs of being improperly backfilled or if settlement occurs, the trenches will be re-opened to a depth required for proper compaction, re-filled and re-compacted, all in accordance with these specifications.
 - c. Compaction tests, taken by an independent commercial laboratory, shall be taken every 1.5 feet of depth and every 300 feet in trench length, or at additional locations the discretion of the District while construction is proceeding. The District shall pick the location and depths at which all compaction tests will be taken. Compaction tests shall be taken at depths below subgrade ranging from one (1) foot above the top of pipe bedding to one (1) foot below grade. The District shall be present when each test is taken and the results shall be forwarded to the District. The contractor shall bear the costs of all compaction tests.
9. Disposal Clean Up
- a. The disposal of unsuitable material and general construction waste shall be the responsibility of the contractor.
 - b. After the work is complete, the construction area shall be cleaned and revegetated.
10. Abandonment of Sanitary Sewer Service Line or Tap

- a. Procedures to abandon an unused sanitary sewer service tap include removal of the service pipeline to within six inches of the sewer main and sealing the service tap stub-out with a mechanical plug or cap, as is appropriate for the existing service material.
 - b. Sewer taps that have been pre-installed that are no longer to be used must be properly abandoned at the time the lot is developed and prior to activation of the service to the property.
11. General Warranty and Trench Maintenance
- a. For a period of one (1) year from the date of final approval of the project by the District, workmanship, materials and equipment incorporated in the project shall be guaranteed by the property owner to remain in normal working order and condition. If a repair is made due to warranty issues, the one-year warranty period is extended from the date the repair is completed.
 - b. For a period of one (1) year from the date of final approval of the project by the District, the contractor shall maintain and repair any trench settlement which may occur and shall make suitable repairs to any pipe, fitting, valve, valve box, pavement, sidewalks, or other structure which may be damaged as a result of backfill settlement as determined by the District or the District's engineer.
- D. Sewer Service Line Testing Procedures
1. Sewer service leak testing is required unless waived by the District. The District will review the required procedures with the contractor prior to the work.
 2. New sanitary sewer service lines larger than 4 inches in diameter shall be cleaned by jetting, and then video inspected. A video DVD of the sewer inspection shall be provided to the District within seven (7) days of the date of video inspection.
 3. Sewer cleaning and video inspections shall be performed by a qualified and District approved contractor.
 4. Sewer vacuum testing shall be performed using extreme care and follow safety precautions during all testing operations. Sewer vacuum testing shall be in accordance with ASTM C-124.
- E. Grinder Pumps
1. If a grinder pump is required, the connection to the sewer main shall conform to Detail S-5.
 2. The service line shall be HDPE pipe, SDR11.
- F. Grease Interceptor
1. Contractor shall comply with UPC. The Uniform Plumbing Code.
 2. Notify the District and allow time for inspection prior to burying grease trap.
 3. Riser from grease trap shall be vertical and sealed with Ramneck. See Detail S-6.
 4. There must be no infiltration or inflow.
 5. The owner is responsible for regular inspection and required cleaning.

Section VIII Wastewater Pumping Stations**A. General**

1. Wastewater pumping stations are generally discouraged and will not be permitted within the District if viable option(s) exist for gravity wastewater service. For the purposes of this Regulation, the District will generally consider the gravity sewer alternative for service as viable if the total construction cost of the gravity sewer service is equal to or less than three times the total construction cost of the wastewater pumping station.
2. Wastewater pumping stations serving a single family residence, with total demand of less than 500 gallons per day, may be subject to different requirements than described herein, and the Owner should contact the District to determine the applicable requirements. If a wastewater lift station is determined by the District to be an acceptable means to provide wastewater service to the project area, the proposed lift station must be approved by the District and meet all requirements of the State of Colorado and other applicable regulatory authorities. Proposed wastewater pumping facilities will be reviewed for consideration on an individual basis.
3. Wastewater pumping stations shall be owned, operated, and maintained by the property owner(s) served by the pumping stations. As part of the approval process for wastewater pumping stations, the operator must provide the District, on an annual basis, documentation that qualified personnel or firms are contracted to perform the necessary operation and maintenance procedures to assure the continued operation of the wastewater pumping station for the following year.
4. The following note shall be placed on subdivision plans for lots that require wastewater pumping for service:

“There is no gravity wastewater service to Lots XXX. A wastewater pumping station is required to serve the property.”
5. On-site retention of wastewater for all wastewater pumping stations shall be provided. The size and capacity of on-site retention will be determined by pump station size, distance from wastewater treatment plant, and location of pump station site, etc.
6. The station must be readily accessible for maintenance vehicles under all weather conditions. The facility should be located off the traffic way of streets and alleys. Security fencing and access hatches with locks shall be installed.
7. Lift station materials and equipment shall be in accordance with District regulations and other applicable state and local regulations.

B. Design Report

1. The District will require a basis of design report be submitted for review that contains detailed plans, specifications, and operation and maintenance information. The contents of the basis of design report shall include, but is not necessarily limited to, the following:
 - a. Average and peak flow calculations for present and ultimate design conditions for contributory areas.
 - b. Wet well configuration and size.

- c. Number, type, capacity, motor horsepower, and Net Positive Suction Head (NPSH) requirements of proposed pumping units. Motors shall be protected from over-current, over-temperature, and voltage imbalance.
 - d. System head curve and head computations for design conditions of pumping system. (Future pumping capacity requirements should be considered in sizing the pumping equipment.) System head calculations shall include the size and length of force main static head and all dynamic losses.
 - e. Pump curve selection, efficiencies, and NPSH characteristics.
 - f. Calculations showing flotation potential and proper ballasting.
 - g. Description of primary and back-up power sources.
 - h. Description of ability to store wastewater during an outage of the lift station, such that there is no damage to persons or property.
 - i. Plan showing the location of the pumping station, force main, wastewater storage capacity, and pertinent elevations.
 - j. Elevation of high water at the site (100-year flood elevation).
 - k. Maximum elevation of wastewater in the collection system and wet well in the event of a power failure for the estimated duration of power outage.
 - l. Detailed electrical and control system plans.
 - m. Detailed plans for the force main (with profile, connecting to outfall location).
 - n. Detailed plans for the pumping station building and all appurtenances.
 - o. Test borings and groundwater elevations.
 - p. A plan of operation and sequence of events for continuous and safe transfer of wastewater during the construction.
 - q. Wastewater pumping station operation and maintenance information, and operation and maintenance plan.
- C. Wastewater Pumping Station - The wastewater pumping station shall include the following provisions:
- 1. Facility Type – Sewage pumping stations of the wet well/dry well and submersible types may be considered.
 - 2. Structures
 - a. Wet and dry wells, including their superstructure, should be completely separated. Common walls must be gas tight.
 - b. Provision shall be made to facilitate removing pumps, motors, and valves.
 - c. Suitable and safe means of access shall be provided to dry wells of pump stations and wet wells containing either bar screens or other mechanical equipment requiring inspection or maintenance. Ventilation is required in both types of wells. Stairways are preferred over ladders for access.
 - d. Housing for pumping equipment and controls shall be readily accessible and weather-proof.
 - e. Where wastewater must be pumped prior to grit removal, the wet well and the discharge piping shall be designed to prevent grit accumulation.
 - f. Where high groundwater conditions are anticipated, buoyancy of the wastewater pumping station should be considered and adequate protections provided if necessary. Geotechnical investigations shall

- provide documentation of the groundwater conditions.
- g. Provision must be made for emergency storage of raw sewage or portable pumping in the event of an extended power outage or electrical or mechanical failure. Discharge structures are prohibited. To make determination of the requirements, consideration will be given to the proximity of the pumping station to surface waters and the designated use of such surface waters including immediate downstream users and the alarm system installed, emergency response procedures, and response time of the entity to an emergency.
3. Pumps
- a. At least two (2) pumps must be provided. If only two (2) units are provided, they should have the same capacity. Each pump shall be capable of handling flows in excess of the expected maximum flow. Where three (3) or more pumps are provided, they should be designed to fit actual flow conditions and must be of such capacity that with one (1) pump out of service, the remaining pumps will have capacity to handle the design peak hourly wastewater flows. For ejector-type lift stations, at least two (2) pneumatic ejectors and compressors are required. Also, the pump sizing should allow for a velocity of at least two (2) feet per second in the force main.
 - b. Readily accessible screens with clear openings selected to protect the pumps should precede pumps handling raw wastewater, unless pneumatic ejectors are used or special devices such as comminutors are installed to protect the pumps from clogging or damage. Where screens are located below ground, convenient facilities must be provided for handling screenings. For the larger or deeper stations, duplicate units of proper capacity are preferred.
 - c. Pumps should be capable of passing spheres of at least three (3) inches (8 centimeters) in diameter unless other equipment is provided to prohibit such solids from entering the suction side of the pump. Pump suction and discharge openings shall be at least four (4) inches (10 centimeters) in diameter for conventional non-clogging pumps.
 - d. The pump should be so placed that under normal operating conditions it will operate under a positive suction head. The NPSH and suction lift requirements of the pumps shall be considered.
 - e. Electrical equipment in enclosed places where gas may accumulate shall comply with the latest National Fire Protection Association (NFPA) codes or the latest National Board of Fire Underwriters' specifications for hazardous locations or submersible locations. Electrical equipment for pump motors should contain elapsed time meters.
 - f. Each pump should have an individual intake. Wet well design should be such as to avoid turbulence near the intake and cavitation in the pump.
 - g. A separate sump pump shall be provided in dry wells to remove leakage or drainage with the discharge to the wet well above the overflow level of the wet well. Water ejectors connected to a potable water supply will not be approved. Floor and walkway surfaces should have an adequate slope to

- the drainage point.
- h. The pumps and controls of main pumping stations, and especially pumping stations operated as part of a treatment works, should be selected to operate at varying delivery rates to permit discharging wastewater from the station to the treatment works at approximately the rate of delivery to the pump station. The hydraulic constraints of downstream treatment works must be considered for peak pumping rates to prevent overloading.
 4. Controls -- Liquid level controller activators should be located so that they will not be affected by flows entering the wet well or by the suction of the pumps. Float tubes in dry wells shall extend high enough to prevent overflow. In small stations with duplicate units, provisions should be made to provide automatic alternations of the pumps in use.
 5. Valves – Suitable shutoff valves shall be placed on suction and discharge lines of each pump. A check valve or pump control valve shall be placed on each discharge line between the shutoff valve and the pump. Suction shutoff valves may not be needed on vacuum primed pumps, self-primed pumps or submersible pumps.
 6. Wet Wells
 - a. Where continuous pump station operation is required, consideration should be given to dividing the wet well into two sections, properly interconnected, to facilitate repairs and cleaning.
 - b. The effective capacity of the wet well should provide a holding period not to exceed 30 minutes for the design minimum flow. Smaller wet wells may be considered when utilizing variable capacity pumping systems. For large peak flow ratios, extended pumping ranges or extended holding times will be considered.
 - c. The wet well floor should have a minimum slope of 1 to 1 to the hopper bottom. The horizontal area of the hopper bottom should be no greater than necessary for proper installation and function of the pump inlet.
 7. Ventilation
 - a. Adequate ventilation shall be provided for all pump stations to mechanically ventilate the dry well. If screens or mechanical equipment requiring maintenance or inspection are located in the wet well, it shall be mechanically ventilated. There shall be no interconnect between the wet well and dry well ventilating systems. In pits over 15 feet (4.5 meters) deep, multiple inlets and outlets are desirable. Dampers should not be used on exhaust or fresh air ducts, and fine screens or other obstructions in the air ducts should be avoided to prevent clogging. Switches for operation of ventilation equipment should be marked and located conveniently. Consideration should be given to automatic controls where intermittent operation is practiced. Consideration should be given to installing heating equipment.
 - Wet Wells: - Where mechanical wet well ventilation is required, it should be continuous and should provide at least 12 complete air changes per hour. For intermittent operation, at least 30 complete air changes per hour should be provided.

- Dry Wells: - Ventilation may be either continuous or intermittent. For continuous operation, at least six (6) complete air changes per hour should be provided. For intermittent operation, at least 30 complete air changes per hour should be provided.
8. Flow Measurement – Pumping stations should have suitable devices for measuring, recording and totaling sewage flow and power consumption. However, hourly use recording shall be considered for a maintenance program.
 9. Water Supply – There shall be no physical connection between any potable water supply and a sewage pumping station, which under any conditions might cause contamination of the potable water supply. If a potable water supply is brought to the station, it shall comply with all applicable regulations.
 10. Power Supply – Power supply must be available from at least two (2) independent generating sources (two (2) different sub-stations), or emergency power equipment shall be provided. The need for automatic starting versus manual starting of emergency power equipment shall be evaluated for each project.
 11. Alarm Systems – Alarm system shall be provided for pumping stations. The alarm shall be activated in case of power failure, pump failure, or any cause of pump station malfunction. Alarms should be tele-metered to the party responsible for the pump station operation. Additionally, an audiovisual device (e.g. horn or light) should be installed at the station for external observation unless disallowed by local ordinance.
- D. Force Mains - Proposed pumping stations and force mains shall be designed and tested to conform to potable water line criteria and the following minimum requirements.
1. Velocity – At design, average flow velocity of at least two (2) feet per second shall be maintained.
 2. Air Relief Valves – An automatic air relief valve shall be placed at high points in the force main to prevent air locking.
 3. Termination – Force mains should enter the gravity sewer system at a point not more than two (2) feet above the flow line of the receiving manhole.
 4. Design Pressure – The force main and fittings, including reaction blocking, shall be designed to withstand normal pressure and pressure surges (water hammer).
 5. Design Friction Losses – Friction losses through force mains shall be based on the Hazen-Williams formula or other acceptable method. When initially installed, force mains will have a significantly higher “c” factor. The higher “c” factor should be considered.
 6. Separation of Water Mains – The separation from water mains shall be the same as gravity sanitary sewer lines.
 7. Where force mains are constructed of material which might cause the force main to be confused with potable water mains, the force main should be appropriately identified.
 8. Utility line markers are to be used on all cross-country or on utility wastewater lines where development has not yet been established to locate the line of the existing/proposed wastewater line.

Appendix

Standard Details

- G-1 Pipe Encasement Detail
- G-2 Trench Detail
- G-3 Reinforced Pipe Encasement Detail
- G-4 Trace Wire
- W-1 Water Service Installation, Single Family Residence
- W-2 Water Service Installation, Multi-Family or Commercial Development
- W-3 Fire Hydrant Setting Detail
- W-4 Service Line, Stop box, and Inside Meter Installation for Single Family Residence
- W-5 Valve Box Installation
- W-6 Concrete Kickblocks Bearing Surfaces and Installation
- W-7 PRV Vault
- W-8 Pipe Insulation Detail
- I-1 Common Area Irrigation Meter
- S-1 Single Family Residence Sewer Service Connection Detail
- S-2 Outside Drop Manhole
- S-3 Sewer Manhole
- S-4 24" Manhole Ring and Cover
- S-5 Grider Pump Connection Detail
- S-6 Grease Interceptor

Exhibits

- A Equivalent Single Family Unit Assessment Schedule
- B Fee Schedule
- C Application for Water and Wastewater Service
- D Service Area Definition
 - D.1 Vicinity Map
 - D.2 Service Area map
- E Application for Water and Sewer Main Plan Review
- F Certification of Substantial Completion
- G Certification of Final Completion
- H District Equipment & Personnel Charges
- I Preconstruction Meeting Agenda
- J Progress Meeting Agenda

Standard Details

Exhibits

EXHIBIT A

<u>Use</u>	<u>ESFU Assessment</u>
Detached Home/Townhome/Duplex/Manufactured Home (up to 3 bedrooms, 2 bathrooms, 1 kitchen)	
-Three bedrooms or less	1.00
-Each bedroom in excess of three	0.20
-Each bathroom, or portion thereof, in excess of two	0.20
-Each kitchen in excess of one	0.50
Apartment or Condominium (each unit up to 2 bedrooms, 2 bathrooms, 1 kitchen)	
-Two bedrooms or less	1.00
-Each bedroom in excess of two	0.32
-Each bath, or portion thereof, in excess of two	0.32
Studio Apartment /Affordable Housing Unit/Divisible Unit	
-Single room less than 650 square feet with one bathroom	0.70
Lodge, Hotel, Motel, Condo-Hotel (No Full Kitchen) - per rental room	0.60
Pool - each	0.60
Hot tub - each	0.20
Restaurant, Lounge, Snack Bar, Delicatessen	
-500 square feet or less	1.00
-Each square foot in excess of 500 square feet	0.003
Movie Theater - per seat	0.02
Automobile Service Station - without car wash	
-Four fuel nozzles or less	1.50
-Each fuel nozzle in excess of four	0.20
Automobile Service Station/Retail Combination - without car wash	
-Four fuel nozzles or less	1.50
-Each fuel nozzle in excess of four	0.20
-Retail space per 1,000 square feet	0.50
Self-Service Laundromat - per washing machine	1.30
Beauty Salon/Hairdresser - per station	0.35
Fire Station, Maintenance Building, Warehouse - per 1,000 square feet	0.15
Office/Office Building - per 1,000 square feet	0.75
Retail Store - per 1,000 square feet	0.50
Ski Rental Shop - per 1,000 square feet	0.75
Doctor Office, Dentist Office - per 1,000 square feet	1.00
Undesigned Commercial Space - per 1,000 square feet	0.50
School	
-Without cafeteria or showers - per student	0.04
-With cafeteria, gym and/or swimming pool - per student	0.06
Day Care Center - per unit of child care capacity	0.04
Church, Conference/Meeting/Banquet Room (and similar facilities without in-house food serving capabilities - per 1,000 square feet)	0.30
Church, Conference/Meeting/Banquet Room (and similar facilities with in-house food serving capabilities - per 1,000 square feet)	0.40
Ski Area, summation of ESFUs from other applicable use categories plus 85% of total hourly lift capacity times	0.001
Health Spa/Fitness Center - per 1,000 square feet	1.50
Bowling Alley	0.50
Travel Trailer Park	
-Without individual water and sewer hookups - per space	0.20
-With individual water and sewer hookups - per space	0.25
Car Wash (coin operated) - per stall	2.00

Winter Park Water & Sanitation District
Equivalent Single Family Unit Assessment Schedule

EXHIBIT A

Notes:

- 1) The 1.00 ESFU is based on usage of 350 gallons of water per day. If usage is beyond reasonable and customary, the District reserves the right to re-evaluate the assessment.
- 2) The minimum ESFU assessment per account will be .5 tap.
- 3) Other types of assessment will be determined by the Board based on projected use.
- 4) Combinations of above are additive.
- 5) A Divisible Unit (listed above with Studio and Affordable Housing) is defined as a single living unit which contains rooms or areas which can be used independent of the remainder of the dwelling, such as having separate entrances, stairways, or lock-off potential.
- 6) A Loft (or mezzanine) shall be considered as one bedroom for the purpose of assessment calculation. A loft is defined as an intermediate floor placed in any story or room not to exceed 33% of the total floor area in that room (according to Uniform Building Code).
- 7) The above schedule does not address all amenities which may be contained in a building (for example swimming pool, handball courts, tennis courts, exercise rooms, spas, hot tubs) or common elements (for example drinking fountains, public restrooms, lounge areas) which benefit owners, residents and guests. These will be considered for assessment on a case-by-case basis.
- 8) Irrigation is defined as exterior use of water for landscaping watering. See General Section 4, Item C for more detailed information on Irrigation.
- 9) Monthly service fees are to be paid year round, and start the first of the month after tap fee payment is due. An allowance is made for a construction period; the District will charge one-half the regular monthly service fee rate for the first six-month period, or when the Certificate of Occupancy is issued, whichever ever comes first. Then, regular monthly service fee rates will take effect.



WINTER PARK WATER and SANITATION DISTRICT

P. O. Box 7

Winter Park, CO 80482

Office Phone: 970-726-5041 or 970-887-2970

2026 FEE SCHEDULE

PLAN REVIEW FEE

Detached Home/Townhome/Duplex/Manufactured Home - No Charge

Multi-Family Structure - \$500 (due upon plan submittal)

Multi-Lot Commercial Development - \$500 for initial review; \$250 for each re-review
(due upon plan submittal)

Previously submitted plans which are the same design as an existing building - \$125
(due upon plan submittal)

PLANT INVESTMENT (TAP) FEES

Water Cost per Equivalent Single-Family Unit	\$11,550
--	----------

Wastewater (Sewer) Cost per Equivalent Single-Family Unit	\$11,550
---	----------

--One (1) ESFU = a detached single-family home/townhome/duplex/manufactured home with up to three bedrooms, two bathrooms, and one kitchen.

--Water and wastewater service fees will be invoiced monthly starting the first of the month following payment of the Plant Investment Fee. As a provision for construction, monthly minimum service fees will be reduced to one-half the rate shown below for the first twelve-month period, or when the Certificate of Occupancy is issued, whichever comes first.

SERVICE FEES (monthly)

Water

Residential:	\$36.98/ESFU/month minimum charge for up to 4,000 gallons
--------------	---

Commercial:	\$22.71/ESFU/month minimum charge for up to 4,000 gallons
-------------	---

Charge for Additional Water used over the minimum: \$6.00/1,000 gallons

Wastewater

Residential and Commercial:	\$42.12/ESFU/month
-----------------------------	--------------------

Plant Investment Fees, Service Fees, and other charges are subject to change by the Board of Directors. Consistent with C.R.S. 32-1-1001(1)(i)(II), taps issued for "affordable housing" which are approved as such by the Town of Winter Park, will be charged 72.5% of the regular taps fee amount for water and sewer taps; provided, however, that prior to the issuance of any taps at the discounted rate for affordable housing, a restrictive covenant shall be signed by the recipient of the tap(s) and recorded in the real estate records as a perpetual encumbrance for the subject property, stating that should the Town give written notice to the District that the property's use as affordable housing has been discontinued or no longer meets the definition of affordable housing established by the Town, and as such definition may be amended in the future, the full tap fee amount shall be due and payable by the holder of the tap within thirty (30) days after the date of said notice. Such restrictive covenant will run with the land and shall be enforceable by the District.

Winter Park Water & Sanitation District
Application for Water and Wastewater Service

Name of Owner
Property Address
Legal Description
Mailing Address
Phone

	Approximate Dates
Building Permit Request	
Utility Construction	
Occupancy (commence water/wastewater service)	

Attach plans and specifications for the proposed building. See Exhibit B (Fee Schedule) for Plan Review Fees.

Any change or modification of plans and specifications require District approval prior to construction.

For projects other than a single family dwelling, the owner/developer/builder should contact District personnel. Most likely, the only plans and specifications required will be site plan, floor plan, elevation, plumbing and irrigation plans.

Construction record drawings must be provided to the District after construction is complete.

A G R E E M E N T

In consideration of the granting of this water and wastewater service, the undersigned acknowledges and agrees:

- 1) To accept and abide by all provisions of Rules and Regulations of the District, including payment of water and wastewater tap fees prior to issuance of building permit by Town of Winter Park. Owner acknowledges that monthly water and wastewater service fees begin the first of the month following payment of tap fees. A reduced minimum service fee for a construction period is outlined in Exhibit B under Plant Investment Fees. Service fee invoices are mailed the first of each month with payment due by the 20th of that month.
- 2) To notify District staff when service lines are ready for inspection and connection to District facilities, and not to cover any portion of the work until the District has made an inspection.
- 3) To maintain water and wastewater service lines at no expense to the District. Service lines include the valve at the District’s water main and the curbstop valve, and from there into the property. The meter assembly is a part of your service line, and includes the ‘Y’ strainer, pressure-reducing valve, and backflow preventor. (District retains ownership of the actual meter.)
- 4) If a backflow preventer is installed, it must be inspected and tested when it is installed, and annually thereafter. The District must receive a copy of the inspection report.

Owner Signature	Date
Owner Signature	Date

Return this completed form to the District at P. O. Box 7, Winter Park, CO 80482

Rev 8/03

Service Area Definition

The following descriptions indicate the basis for the delineation of the Winter Park Water and Sanitation District Service Area boundary shown on the following map.

- A Mary Jane Placer
- B US Forest Service Trade Parcel Tract 43
- C US Forest Service Trade Parcel Tract 41
- D US Forest Service Trade Parcel Tract 42A, 42B, 42C, 42D
- E Town of Winter Park Triangle Subdivision Exemption
- F Lakota Ridge - US Forest Service Trade Parcel Tract 48
- G Raintree Inn - US Forest Service Trade Parcel Tract 46A, 46B, 47
- H City Land Parcel
- I US Forest Service Trade Parcel Tract 44
- J Service to WPRA Mary Jane Shop Buildings
- K Service extension for WPRA Sunspot Facility
- L Service extension for WPRA Snoasis Facility
- M Service extension for WPRA Lunch Rock Facility

Application for Water and Sewer Main Plan Review

Name of Owner
Property Address
Legal Description
Mailing Address
Phone

	Approximate Dates
Building Permit Request	
Utility Construction	
Occupancy (commence water/wastewater service)	

1. Attach plans and specifications for proposed water and/or sewer mains.
2. See Exhibit B (Fee Schedule) for Plan Review Fees.
3. Applicant is referred to Section I-Construction Procedure, Part H Ownership.
4. The plan review, construction phase, construction inspection, and construction approval process will follow this general guideline.
 - a. Applicants will submit a signed Application for Water or Sewer Main Plan Review along with complete plans, specifications, and design report package. Application must be signed by the property owner. The District will review the plan review package and subsequent revisions until the plans are approved.
 - b. Prior to construction, Owner will arrange a pre-construction meeting to review the project, construction requirements, District inspection requirements and general requirements for coordination between the project stakeholders. Required attendees include the property owner, developer, general contractor, water and sewer utility contractor, and District.
 - c. As described in the Rules and Regulations, all water and sewer main construction must be inspected by the District.
 - d. Upon substantial completion of the water and sewer main construction, Owner shall submit to the District a signed Certificate of Substantial Completion along with the required documentation.
 - e. Upon final completion of the water and sewer main construction, Owner shall submit to the District a signed Certificate of Final Completion along with the required documentation.
 - f. Transfer of ownership of water and sewer mains to the District will not occur until the District concurs that the Property Owner has reached Final Completion of the work.
5. Any change or modification of plans and specifications require District approval prior to construction.
6. Construction record drawings must be provided to the District after construction is complete.

Application for Water and Sewer Main Review (con't)
A G R E E M E N T

In submitting this Application for Water or Sewer Main Plan Review, undersigned acknowledges and agrees:

- 1) To accept and abide by all provisions of Rules and Regulations of the District.
- 2) To pay plan review fees at the time plans are submitted for review, including payment of fees for second and subsequent reviews.
- 3) Acknowledges the District policies and procedures described in the Rules and Regulation and the plan review, construction and acceptance procedures summarized in part 4 above.

Owner Signature	Date
Owner Signature	Date

Return this completed form to the District at P. O. Box 7, Winter Park, CO 80482

**Certification of Substantial Completion
Water and Sewer Main Construction**

Name of Owner
Property Address
Legal Description
Mailing Address
Phone

The Owner certifies that the Work is Substantially Complete under the Contract Documents or to the following specified parts thereof (attach additional pages as necessary):

The Owner has identified the following items which still need to be completed (attach additional pages as necessary):

.....

The District has reviewed the Work to which this Certificate applies, that it has been inspected by authorized representatives of the District, and that Work is hereby declared to be substantially complete in accordance with the Contract Documents on this date of:

Date: _____

A tentative list of items to be completed or corrected is attached hereto. This list may not be all-inclusive, and the failure to include an item in the list does not alter the responsibility of OWNER and CONTRACTOR to complete all the Work in accordance with the Contract Documents. The items in the tentative list shall be completed or corrected by OWNER and CONTRACTOR within 15 Contract days of the above date of Substantial Completion.

OWNER and CONTRACTOR shall maintain all contractual responsibilities until Final Acceptance.

The following documents are attached to and made a part of this Certificate of Substantial Completion:

This certificate does not constitute an acceptance of Work or start of the guarantee period nor its release of OWNER and CONTRACTOR'S obligation to complete the Work in accordance with the Contract Documents. Issuance of Substantial Completion does not commence the guarantee period with this certificate.

OWNER

BY: _____

TITLE: _____

DATE: _____

CONTRACTOR

BY: _____

TITLE: _____

DATE: _____

Winter Park Water and Sanitation District

BY: _____

TITLE: _____

DATE: _____

**Certification of Final Completion
Water and Sewer Main Construction**

Name of Owner
Property Address
Legal Description
Mailing Address
Phone

The Owner certifies that the Work has achieved Final Completion under the Contract Documents and forwards the following documentation:

1. Record Drawings
2. Owner's manuals
3. Documentation of transfer of title to mains and associated appurtenances and equipment
4. Documentation of transfer of property having been duly recorded
5. Documentation of Recorded Easements
6. Title Commitment and Title Insurance for property containing easements
7. Verification of payment in full of all plan review fees

.....
.

The District has reviewed the Work to which this Certificate of Final Completion applies, that it has been inspected by authorized representatives of the District, and that Work is hereby declared to be complete in accordance with the Contract Documents and the required documentation has been received on this date of:

Date: _____

This certificate constitutes an acceptance of Work and the start of the guarantee period

WINTER PARK WATER AND SANITATION DISTRICT

BY: _____

TITLE: _____

DATE: _____

District Equipment & Personnel Charges

Laborer	\$35.00/hour
Supervisor	\$50.00/hour
Truck	\$50.00/hour
Miscellaneous Equipment (pump, generator, etc.)	\$20.00/hour
Materials and/or Rental Equipment will be charged at invoiced cost, plus 10%.	
Filling Water Trucks	\$10.00/1,000 gallons

SCHEDULE

- A. Present at the conference to represent the Contractor shall be at least the official in charge of the Project, the project superintendent, a representative with authority to speak for each of his principle Subcontractors, and other representatives as he may deem expedient.
- B. The developer and/or his representatives shall be present as required.
- C. Proceedings of meeting to be recorded by the District and distributed to interested parties.

AGENDA

The District, developer, and contractor shall be prepared to speak to the following as a minimum:

- 1. Name and Field Address of job contactors, developer, District
- 2. Emergency Phone and/or operator
- 3. Date of Construction Start
- 4. Date of Notice to Proceed
- 5. Meter size
- 6. Pipe size
- 7. Meter readout location
- 8. Construction water
- 9. Trench maintenance
- 10. Trench dewatering
- 11. Concrete formwork required
- 12. Trench compaction requirements
- 13. Only District operates valves and hydrants
- 14. Disposal of chlorinated water
- 15. Inspection of all joints, bedding and thrust blocks before backfill
- 16. Concrete cure time (24 hours)
- 17. Clean pipe – cap to keep dirt out.
- 18. Notification of Utilities Concerned Fire, Police, Schools, etc.
- 19. Coordination with other contractors
- 20. Permits: County, City, Government Agencies as required
- 21. Inspector: name, authority
- 22. Shop Drawing Submittals
- 23. Construction progress schedule
- 24. Safety Requirements and Special Hazards
- 25. Traffic Control
- 26. Construction Signs
- 27. Drawings revised to conform to construction records
- 28. Beneficial occupancy
- 29. Retention of Contract records
- 30. Guarantees and warranties
- 31. Operation and Maintenance Manuals
- 32. Project Signs
- 33. Pipe testing requirements, reporting, and responsibility
- 34. Periodic Progress Meetings
- 35. Other matters concerning construction

MEETINGS

- A. Schedule regular progress meetings as required by the District and contractor at mutually agreed time.
- B. Hold called meetings as progress of Work dictates.
- C. Location of meetings: As designated during Preconstruction Conference.
- D. Attendance:
 - 1. Engineer and/or his Consultants
 - 2. Owner (optional)
 - 3. Contractor
 - 4. Other contractors (if any)
 - 5. Subcontractors as pertinent to agenda
 - 6. Safety Representative (Optional)
 - 7. Representatives of Governmental or other Regulatory Agencies (when appropriate)

MINIMUM MEETING AGENDA:

- 1. Review, approve minutes of previous meeting.
- 2. Review work progress since last meeting. Contractor shall identify each specific work item completed, and compare to planned progress from previous meeting.
- 3. Note field observations, problems and decisions.
- 4. Identify problems which impede planned progress.
- 5. Review off-site fabrication problems.
- 6. Develop corrective measures and procedures to regain planned schedule.
- 7. Revise Construction Schedule as indicated.
- 8. Plan progress during next two week work period.
- 9. Coordinate projected progress with other contractors.
- 10. Review submittal schedules.
- 11. Maintaining of quality and work standards.
- 12. Review changes proposed by Owner.
- 13. Complete other current business.

Appendices

2/24/2009 11:50:11 AM T:\PROJECTS\6844633_WP_SD_NEW_GENERAL_SE\SUB_00\9.0_CAD\STANDARDDETAILS\2009 REVISIONS\DETAILG-1.DWG,JIM_HEALY

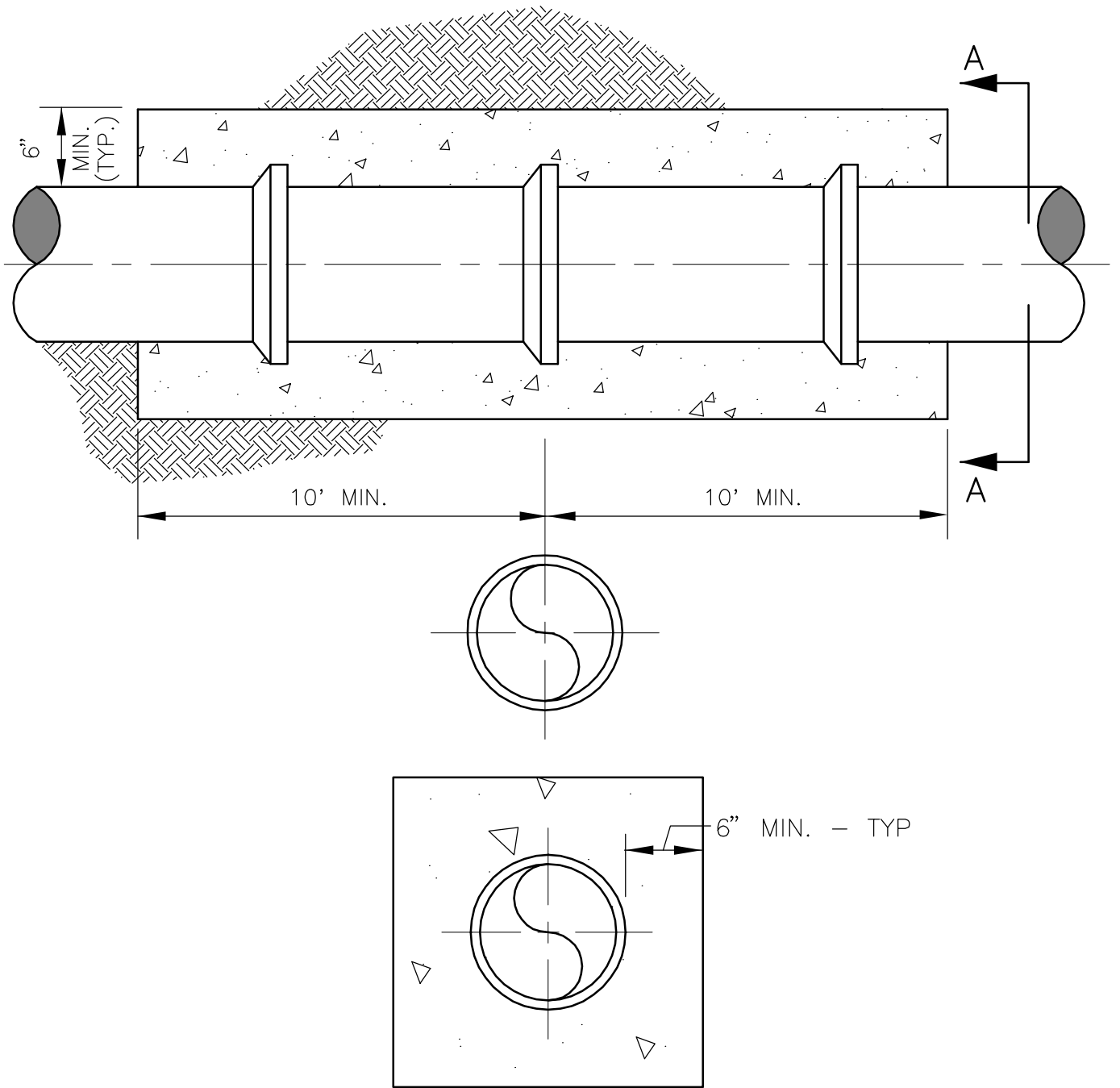

NOTES:

SECTION A-A

1. CONCRETE ENCASUREMENT WILL BE REQUIRED ON SEWER LINE WHEN CLEAR VERTICAL DISTANCE FROM WATER LINE IS LESS THAN 1'-6" OR HORIZONTAL DISTANCE IS LESS THAN 10' BETWEEN WATER AND SEWER PIPELINES. CONCRETE ENCASUREMENT REQUIRED IN ALL CASES WHERE SEWER LINE IS ABOVE WATER LINE OR IS UNDER A WATERWAY CROSSING. CONCRETE MUST BE FORMED. CONCRETE POURED DIRECTLY INTO TRENCH WITHOUT FORMS WILL NOT BE PERMITTED.
2. CONCRETE MUST HAVE A MINIMUM COMPRESSIVE STRENGTH OF 3000psi AFTER 28 DAYS. CONCRETE MUST BE COMPLETELY BATCHED BEFORE PLACING CONCRETE.
3. CONCRETE ENCASUREMENT MUST MEET MINIMUM CONCRETE CURE TIMES BEFORE BACKFILL AND PRESSURIZATION OF THE PIPE. SEE WATER MAIN SPECIFICATION FOR DETAILED REQUIREMENTS.
4. AN ALTERNATIVE TO FULL ENCASUREMENT OF THE SEWER IS TO USE C-900 PVC PIPE FOR THE SEWER PIPE AND ENCASE THE PIPE JOINTS IN 6 INCHES OF CONCRETE FOR TWO FEET EITHER SIDE OF THE JOINT. ALL JOINTS WITHIN 12 FEET OF THE CROSSING SHALL BE ENCASED.
5. SEWER PIPE AND ENCASUREMENT MUST ONLY BE INSTALLED UNDER DRY TRENCH CONDITIONS AS APPROVED BY DISTRICT.

WINTER PARK WATER AND SANITATION DISTRICT	
PIPE ENCASUREMENT DETAIL	
DATE: 2/23/2009	G-1

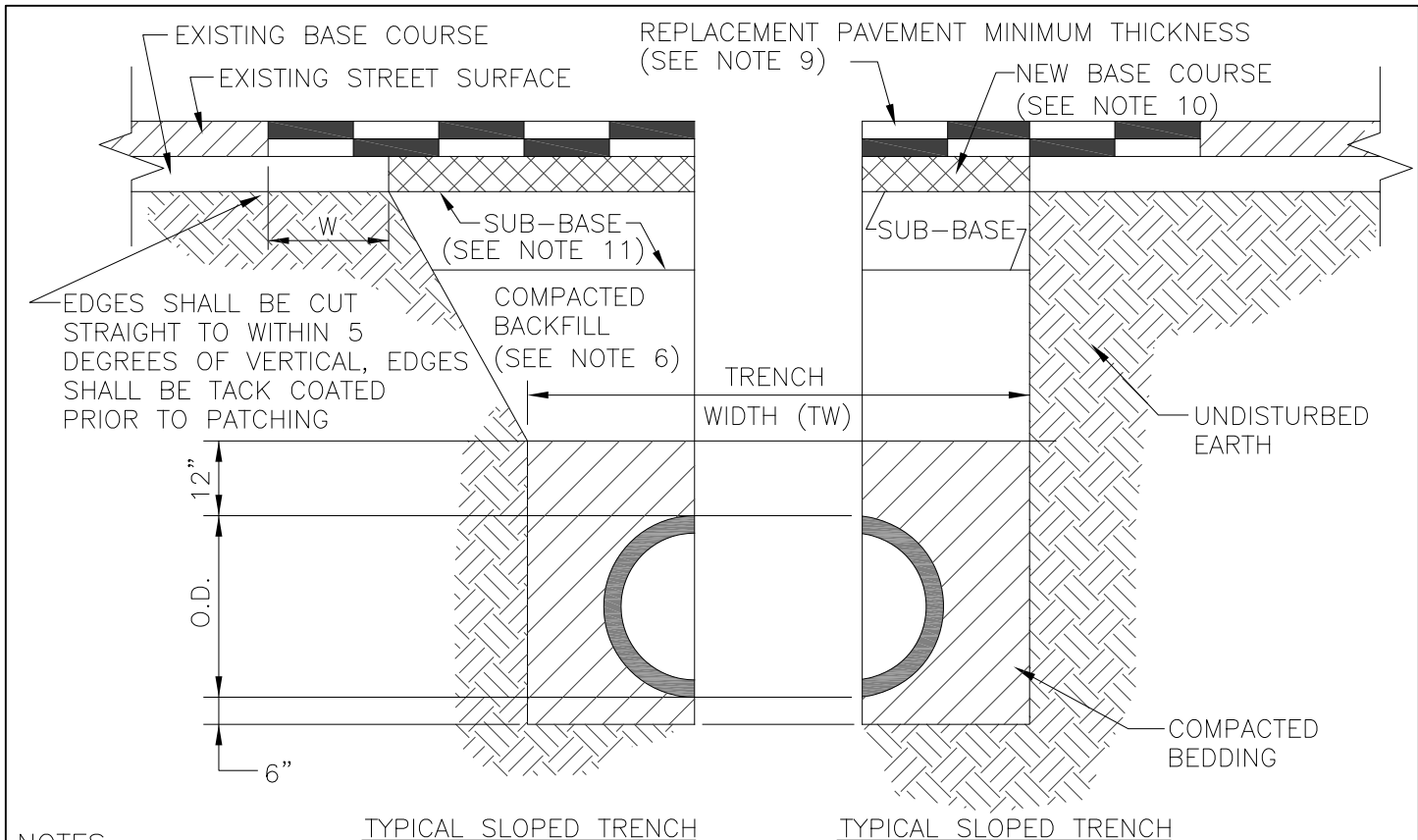

NOTES

1. THIS TRENCH PATCHING DETAIL SPECIFIES REQUIREMENTS IN ADDITION TO THOSE SPECIFIED IN THE LATEST EDITION OF THE C.D.O.T. STANDARD SPECIFICATIONS FOR ROAD AND BRIDGE CONSTRUCTION, WHICH ALSO APPLIES.
2. A CONSTRUCTION TRAFFIC CONTROL PLAN SHALL BE SUBMITTED TO AND APPROVED PRIOR TO ISSUANCE OF CONSTRUCTION PERMITS IN THE TOWN RIGHT-OF-WAY.
3. TRENCH SHALL BE BRACED OR SHEETED AS NECESSARY FOR THE SAFETY OF THE WORKMEN AND PROTECTION OF OTHER UTILITIES OR STRUCTURES IN ACCORDANCE WITH APPLICABLE LOCAL, STATE, AND FEDERAL SAFETY REGULATIONS.
4. THE TRENCH WIDTH SHALL BE CONFINED TO THOSE MINIMUM DIMENSIONS, WHICH WILL PERMIT PROPER INSTALLATION AND ACCEPTABLE PIPE LOADING, AS ESTABLISHED BY CURRENT ACCEPTABLE ENGINEERING PRACTICES.
5. EXISTING ASPHALT OR PAVEMENT SHALL BE CUT BACK TO MINIMUM OF W (SEE ABOVE) BEYOND THE TRENCH LIMITS OR TO SOUND PAVEMENT, WHICHEVER IS GREATER.
6. BACKFILL COMPACTION REQUIREMENTS: MINIMUM DENSITY WILL BE DETERMINED IN ACCORDANCE WITH AASHTO DESIGNATION T-99 OR T180 AS DEFINED BY C.D.O.T. STANDARD SPECIFICATIONS FOR ROAD AND BRIDGE CONSTRUCTION.
7. FULL DEPTH ASPHALT CAN BE USED AS AN ALTERNATIVE TO BASE COURSE. A RATIO OF 3 INCHES BASE COURSE TO 1 INCH OF ASPHALT SHALL BE USED IN THE SUBSTITUTION.
8. A TEMPORARY COLD-MIX ASPHALT PATCH, 4" IN DEPTH, WILL BE REQUIRED FOR ALL STREETS CUTS IF A PERMANENT HOT-MIX ASPHALT PATCH CANNOT BE APPLIED FOR ANY REASON, AFTER CONSTRUCTION IS COMPLETED.
9. HOT MIX ASPHALT CONCRETE: GRADING SX. MATCH EXISTING PAVEMENT OR 3" THICKNESS WHICHEVER IS GREATER.
10. GRAVEL ROAD SURFACE: A MINIMUM OF 6" CLASS C AGGREGATE BASE COURSE MEETING C.D.O.T. STANDARDS.
11. BASE COURSE MATERIAL SHALL BE C.D.O.T. CLASS C MATERIAL.
12. SUB BASE MATERIAL SHALL BE TO C.D.O.T. CLASS 1 OR CLASS 2 MATERIAL. NO MATERIALS LARGER THAN 2-1/2" ARE PERMITTED IN THE SUBBASE ZONE.
13. ALL TRENCH BACKFILL, COMPACTION AND RESURFACING SHALL BE IN ACCORDANCE WITH WINTER PARK STANDARDS.
14. PIPE BEDDING AND BACKFILL MATERIAL SHALL BE PER THESE RULES AND REGULATIONS.

TW	W
LESS THAN 12"	6"
12"-24"	9"
OVER 24"	12"

WINTER PARK WATER AND
SANITATION DISTRICT

TRENCH DETAIL

DATE: 5/6/2015 **G-2**

5/7/2015 10:59:35 AM, T:\PROJECTS\6844633_WP_SD_NEW_GENERAL_SE\SUB_00\9_0_CAD\STANDARDDETAILS\2009 REVISIONS\DETAILG-2.DWG.CHAVEZ, JULIAN

2/24/2009 11:53:09 AM:T:\PROJECTS\6844633_WP_SD_NEW_GENERAL_SE\SUB_00\9.0_CAD\STANDARDDETAILS\2009 REVISIONS\DETAILG-3.DWG,JIM_HEALY

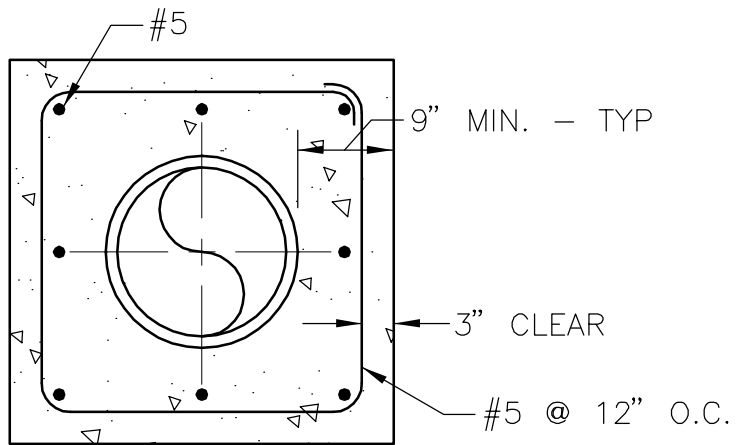
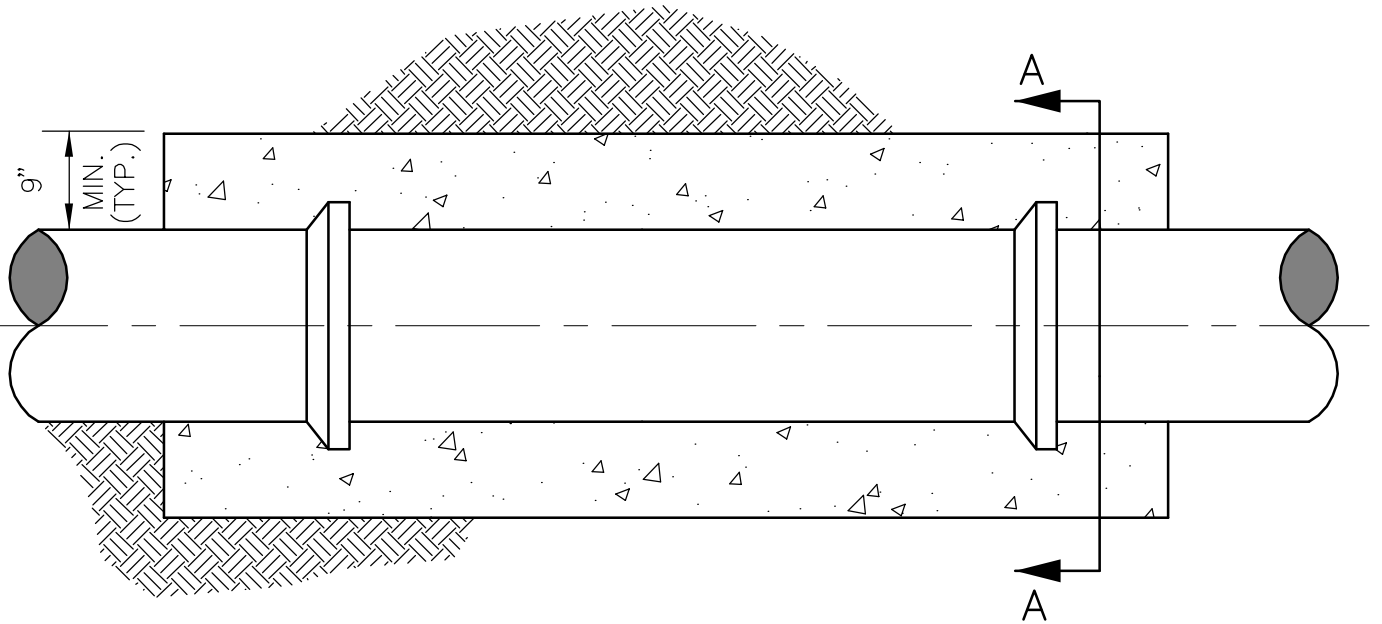

SECTION A-A

NOTES:

1. REINFORCED CONCRETE PIPE ENCASEMENT WHERE REQUIRED BY THE DISTRICT SHALL MEET THE MINIMUM REQUIREMENTS AS DESCRIBED IN THIS DETAIL.
2. CONCRETE MUST HAVE A MINIMUM COMPRESSIVE STRENGTH OF 3000psi AFTER 28 DAYS. CONCRETE MUST BE COMPLETELY BATCHED BEFORE PLACING CONCRETE.
3. CONCRETE ENCASEMENT MUST MEET MINIMUM CONCRETE CURE TIMES BEFORE BACKFILL AND PRESSURIZATION OF THE PIPE. SEE WATER MAIN SPECIFICATION FOR DETAILED REQUIREMENTS.
4. PIPE AND ENCASEMENT MUST ONLY BE INSTALLED UNDER DRY TRENCH CONDITIONS AS APPROVED BY DISTRICT.

WINTER PARK WATER AND SANITATION DISTRICT	
REINFORCED PIPE ENCASEMENT DETAIL	
DATE: 2/23/2009	G-3

**Winter Park Water and Sanitation District
Standard Detail G-4
Tracer Wire**

The following section describes the requirements for tracer wire to be installed along water pipelines, sewer pipelines, water services and sanitary sewer services as described in the regulations.

MATERIALS

Tracer wire

- ◆ **Open Trench Installation** - Tracer wire shall be #12 AWG Copper Clad Steel, High Strength with minimum 450 lb. break load, with minimum 30 mil HDPE insulation thickness.
- ◆ **Directional Drilling/Boring Installation**- Tracer wire shall be #12 AWG Copper Clad Steel, Extra High Strength with minimum 1,150 lb. break load, with minimum 30 mil HDPE insulation thickness.

Connectors

- ◆ All water pipeline and service tracer wires must be interconnected at intersections, at mainline tees, mainline crosses, and service connections.
- ◆ All tracer wire splices, taps or connections shall be soldered and appropriately water proofed with trace wire below grade splice.
- ◆ Non locking friction fit, twist on or taped connectors are prohibited.

Termination/Access

- ◆ All tracer wire termination points must utilize an approved tracer wire access point/box (above ground access box or grade level/in-ground access box as applicable and approved by the WPWSD), and specifically manufactured for this purpose. Access points shall be as manufactures by Copperhead Industries and described in this section. All wire terminations shall be labeled.
- ◆ All grade level/in-ground access boxes shall be appropriately identified with “water” cast into the cap (and be blue in color as applicable for the devices furnished).
- ◆ A minimum of 2 ft. of excess/slack wire is required in all tracer wire access boxes after meeting final elevation grade.
- ◆ All tracer wire access boxes must include a manually interruptible conductive/connective link between the terminal(s) for the tracer wire connection and the terminal for the grounding anode wire connection.

WINTER PARK WATER AND SANITATION DISTRICT	
TRACER WIRE TEST STATION NOTES	
DATE: 11/15/23	G-4a

**Winter Park Water and Sanitation District
Standard Detail G-4
Tracer Wire**

- ◆ Grounding anode wire shall be connected to the identified (or bottom) terminal on all access boxes.
- ◆ Water Service Laterals - Tracer wire must terminate with an approved grounding anode as near as possible to the building entrance. Tracer wire must terminate at an approved Tracer wire access box installed as near as possible to the building, as approved by WPWSD.
- ◆ Hydrants – Tracer wire must terminate at an approved above-ground Tracer wire access box properly mounted to the hydrant grade flange. (Mounting with tape or plastic ties is not acceptable). Schedule 80 PVC shall be used as a conduit extending from the Tracer wire terminal to a point 24” below grade.
- ◆ Tracer wire must be properly grounded at all dead ends/stubs, and as directed by WPWSD.
- ◆ Grounding of tracer wire shall be achieved by use of a drive-in magnesium grounding anode rod with a minimum of 20ft of #12 red HDPE insulated copper clad steel wire connected to anode (minimum 1.5 lb.), specifically manufactured for this purpose, and buried at the same elevation as the utility. ^R
- ◆ When grounding the tracer wire at dead ends/stubs, the grounding anode shall be installed in a direction 180 degrees opposite of the tracer wire, at the maximum possible distance.
- ◆ When grounding the tracer wire in areas where the tracer wire is continuous and neither the mainline tracer wire or the grounding anode wire will be terminated at/above grade, install grounding anode directly beneath and in-line with the tracer wire. Do not coil excess wire from grounding anode. In this installation method, the grounding anode wire shall be trimmed to an appropriate length before connecting to tracer wire with a mainline to lateral lug connector
- ◆ Where the anode wire will be connected to a tracer wire access box, a minimum of 2 ft. of excess/ slack wire is required after meeting final elevation grade.

INSTALLATION

General

- ◆ Tracer wire installation shall be performed in such a manner that allows proper access for connection of line tracing equipment, proper locating of wire without loss or deterioration of low frequency (512Hz) signal for distances in excess of 1,000 linear feet, and without distortion of signal caused by multiple wires being installed in close proximity to one another.
- ◆ Tracer wire systems must be installed as a single continuous wire, except where using approved connectors. No looping or coiling of wire is allowed along the mainline installation.
- Any damage occurring during installation of the Tracer wire must immediately be brought to the attention of the WPWSD and subsequently repaired immediately by removing the damaged wire and installing a new section of wire with approved connectors. Taping and/or spray coating wire is not allowed.

WINTER PARK WATER AND SANITATION DISTRICT	
TRACER WIRE TEST STATION NOTES	
DATE: 11/15/23	G-4b

**Winter Park Water and Sanitation District
Standard Detail G-4
Tracer Wire**

- ◆ Tracer wire shall be installed at the top of the pipe and secured to the pipe (taped/plastic ties) at 5' intervals.
- ◆ Lay mainline tracer wire continuously, by-passing around the outside of valves and fittings.
- ◆ Tracer wire must be properly grounded as specified.
- ◆ Tracer wire on all service laterals/stubs must terminate at an approved grounding anode and tracer wire access box located directly above the utility, at locations approved by WPWSD.
- ◆ A mainline tracer wire must be installed, with all service lateral tracer wires properly connected to the mainline tracer wire, to ensure full tracing/locating capabilities from a single connection point.
- ◆ At all mainline dead-ends, tracer wire shall go to ground using an approved connection to a drive-in magnesium grounding anode rod, buried at the same depth as the tracer wire.
- ◆ Mainline tracer wire shall not be connected to existing conductive pipes.
- All service lateral tracer wires shall be a single wire, connected to the mainline tracer wire using a mainline to lateral lug connector, installed without cutting/splicing the mainline tracer wire.
- In occurrences where an existing tracer wire is encountered on an existing utility that is being extended or tied into, the new tracer wire and existing tracer wire shall be connected using approved splice connectors, and shall be properly grounded at the splice location as specified.

PROHIBITED PRODUCTS AND METHODS

The following products and methods shall not be allowed or acceptable

- ◆ Uninsulated tracer wire
- ◆ Tracer wire insulation other than HDPE
- ◆ Tracer wire not domestically manufactured
- ◆ Non locking, friction fit, twist on or taped connectors
- ◆ Wire connections utilizing taping or spray-on waterproofing
- ◆ Looped wire or continuous wire installations, that has multiple wires laid side-by-side or in close proximity to one another
- ◆ Tracer wire wrapped around the corresponding utility
- ◆ Brass fittings with tracer wire connection lugs
- Wire terminations within the roadway, i.e. in valve boxes, cleanouts, manholes, etc., unless approved by WPWSD.
- ◆ Connecting tracer wire to existing conductive utilities

WINTER PARK WATER AND SANITATION DISTRICT	
TRACER WIRE TEST STATION NOTES	
DATE: 11/15/23	G-4c

**Winter Park Water and Sanitation District
Standard Detail G-4
Tracer Wire**

TESTING

- All new tracer wire installations shall be located using typical low frequency (512Hz) line tracing equipment, witnessed by the contractor, engineer and WPWSD prior to acceptance of the work by WPWSD.
- This verification shall be performed upon completion of rough grading and again prior to final acceptance of the project.
- Continuity testing in lieu of actual line tracing shall not be accepted.

FIGURES

Figures showing tracer wire requirements follow.

R

WINTER PARK WATER AND SANITATION DISTRICT	
TRACER WIRE TEST STATION NOTES	
DATE: 11/15/23	G-4d



UNLESS SHOWN OTHERWISE ON PLAN, CONNECT TRACE WIRE TO MAGNESIUM GROUNDING ANODE AT ALL NEW SERVICES AND RECONNECTS LONGER THAN 10 FEET.

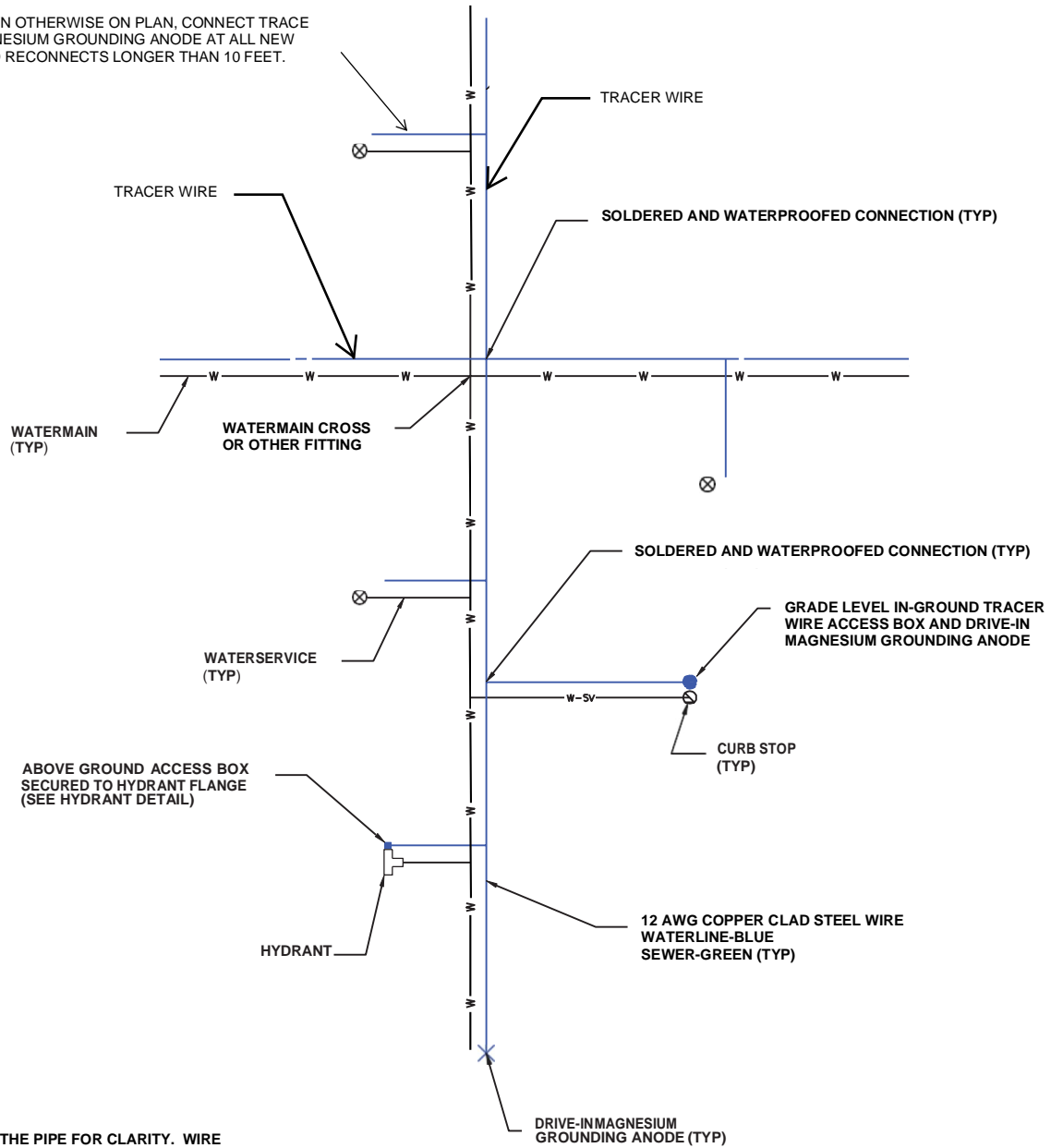

NOTES:

1. WIRE IS SHOWN AWAY FROM THE PIPE FOR CLARITY. WIRE SHALL BE INSTALLED ON THE TOP OF THE PIPE.

2. WIRE SHALL BE FASTENED TO THE PIPE WITH TAPE OR PLASTIC TIES AT 5 FT INTERVALS.

WINTER PARK WATER AND
SANITATION DISTRICT

TRACER WIRE TEST STATION
WATER SYSTEM

DATE: 11/15/23

G-4e

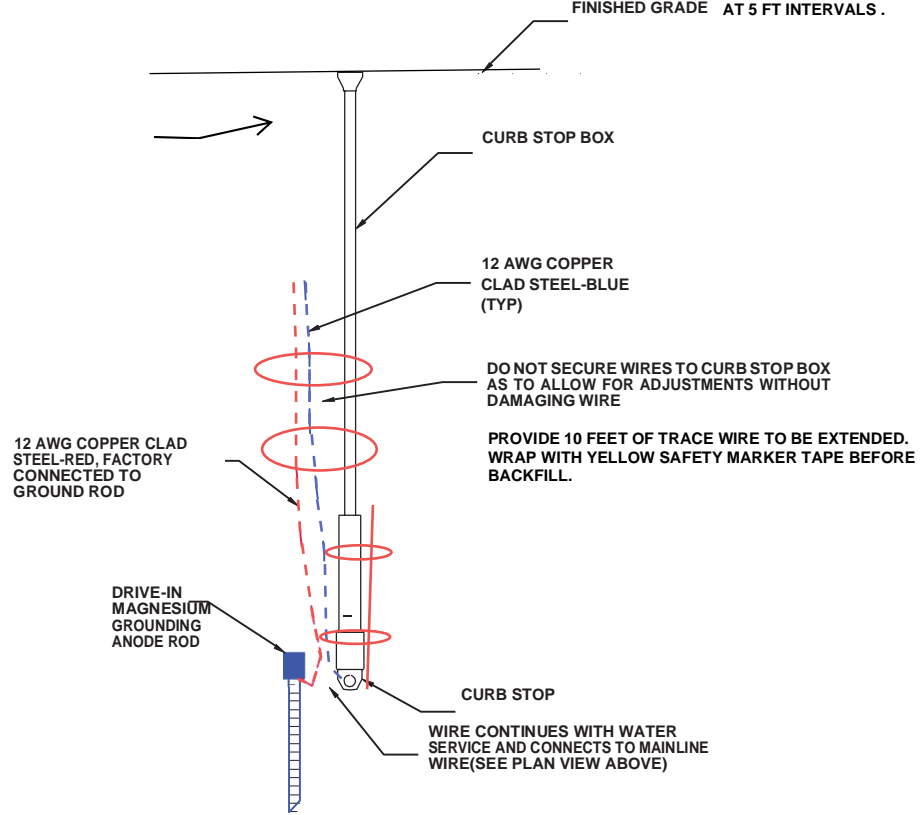
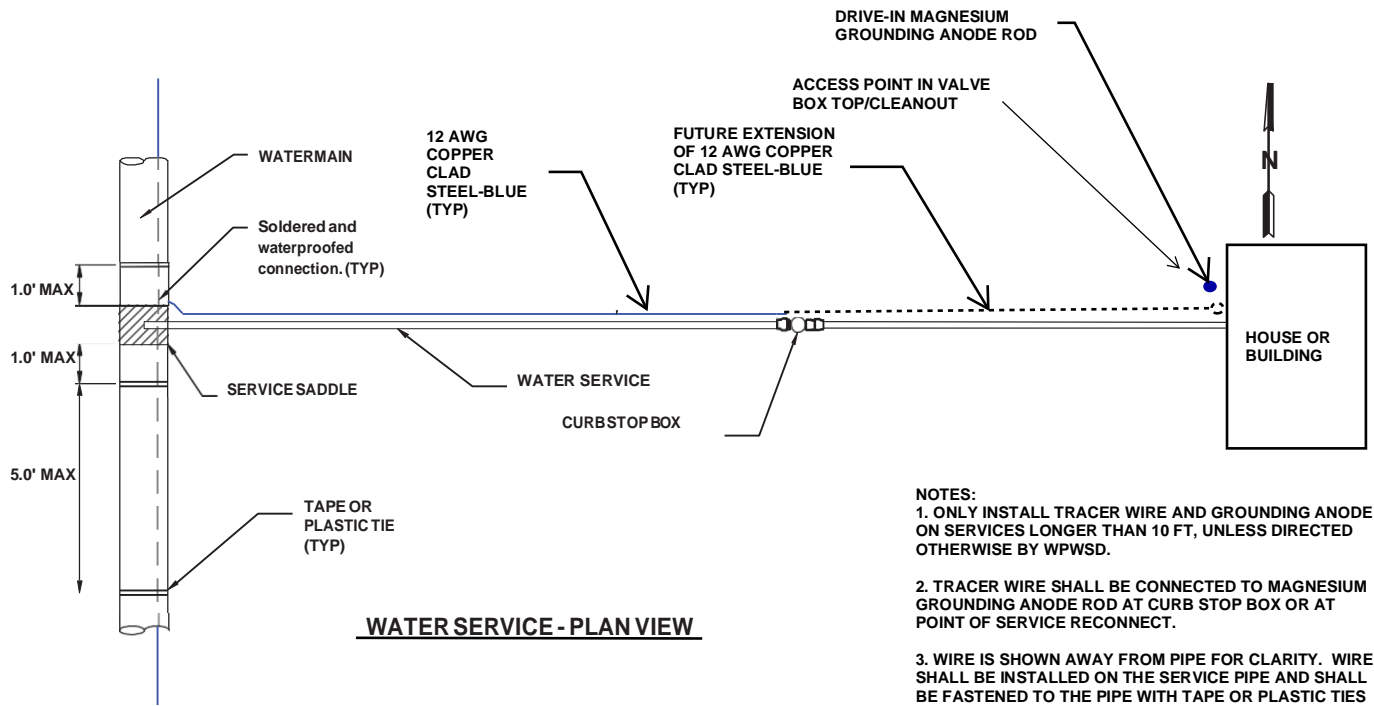

WINTER PARK WATER AND SANITATION DISTRICT	
TRACER WIRE TEST STATION WATER SYSTEM	
DATE: 11/15/23	G-4f

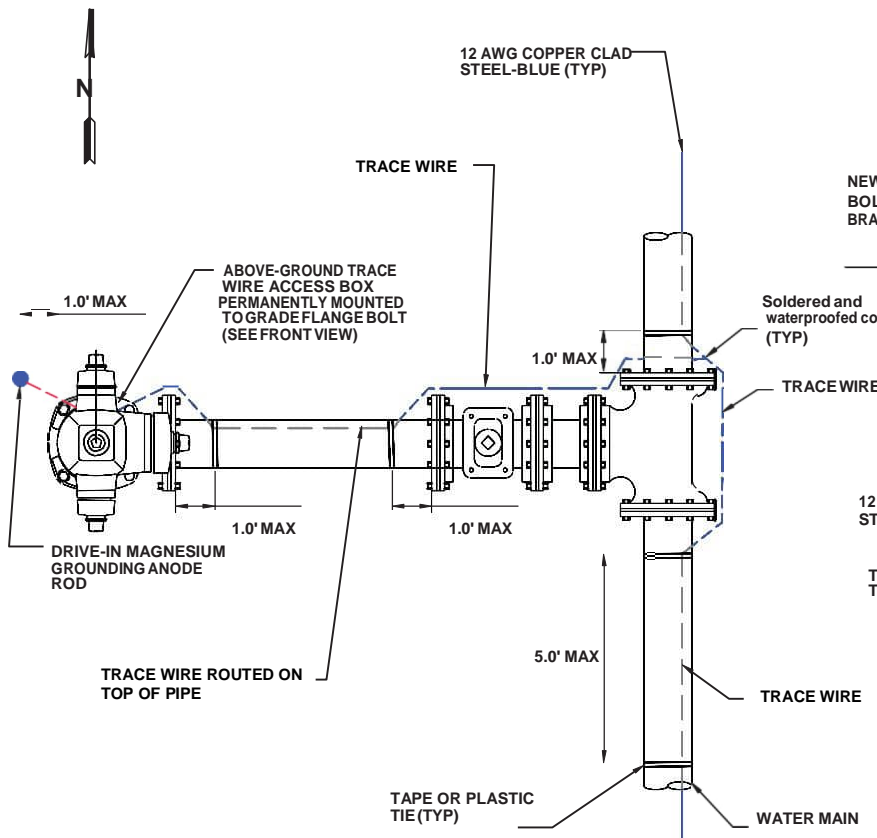

HYDRANT - PLAN VIEW

NO SCALE

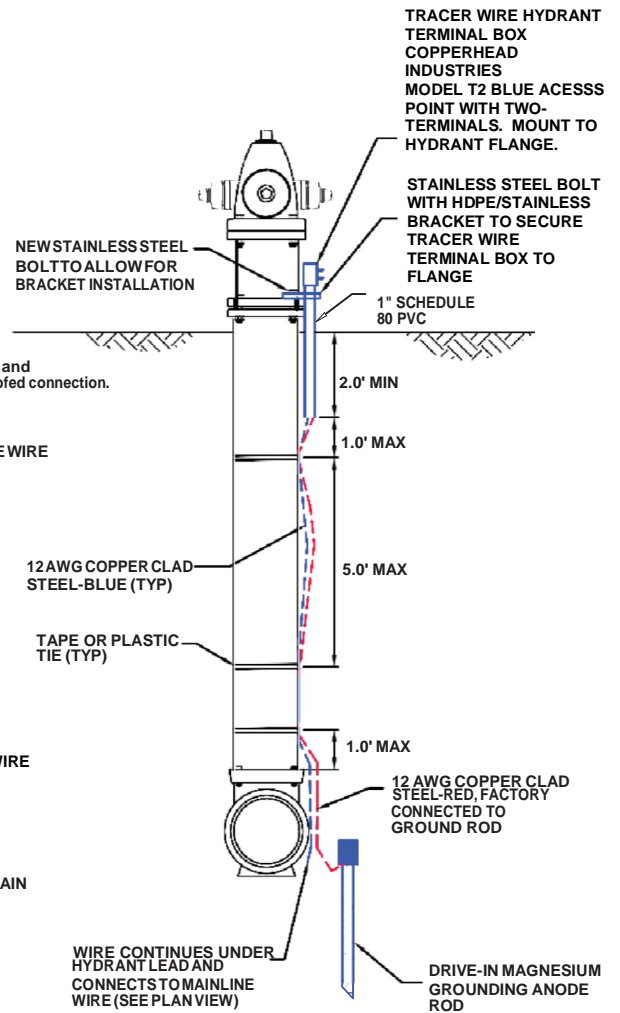

HYDRANT - SECTION VIEW

NO SCALE

WINTER PARK WATER AND
SANITATION DISTRICT

**TRACER WIRE ACCESS POINT
ON HYDRANT DETAIL**

DATE: 11/15/23

G-4g

TRACER WIRE TERMINAL BOX
 COPPERHEAD INDUSTRIES
 MODEL LD14*2T-SW, SNAKEPIT LITE DUTY
 ACCESS POINT WITH TWO-TERMINAL
 SWITCHABLE LID. INSTALL IN CAST IRON
 VALVE BOX UNDER VALVE BOX LID.

5 1/4" ID SLIP-TYPE CAST IRON
 VALVE BOX TOP AND BOTTOM
 SECTIONS (RECESS 1/4" BELOW
 PAVEMENT)

4.3"

NOTE 2

GRADE/PAVEMENT

PROVIDE A MINIMUM OF 2 LINEAL
 FEET OF ADDITIONAL TRACER
 AND GROUND WIRES COILED IN
 SNAKEPIT ACCESS POINT BODY

#8 AWG CU GROUNDING BOND,
 OR LARGEST RECOMMENDED BY
 SNAKEPIT MANUFACTURER.

USE SQUEEGE BACKFILL IN
 VALVE BOX TO SUPPORT
 SNAKEPIT ACCESS POINT TO
 THE PROPER GRADE

GROUND ROD FOR TRACER WIRE
 TERMINAL BOX

WIRE BONDING TO TRACING WIRE
 TO BE EQUAL TO OR LARGER
 THAN TRACING WIRE.

TRACER WIRE

Notes:

1. LOCATE TRACER WIRE TERMINAL BOX 3 FT OFFSET FROM THE PIPE CENTERLINE. COORDINATE LOCATION WITH WPWSD PRIOR TO CONSTRUCTION.

2. SNAKEPIT ACCESS POINT COLOR: WATERLINE TRACER-BLUE, SEWER TRACER-GREEN

WINTER PARK WATER AND
 SANITATION DISTRICT

TRACER WIRE ACCESS POINT IN
 VALVE BOX DETAIL

DATE: 11/15/23

G-4h

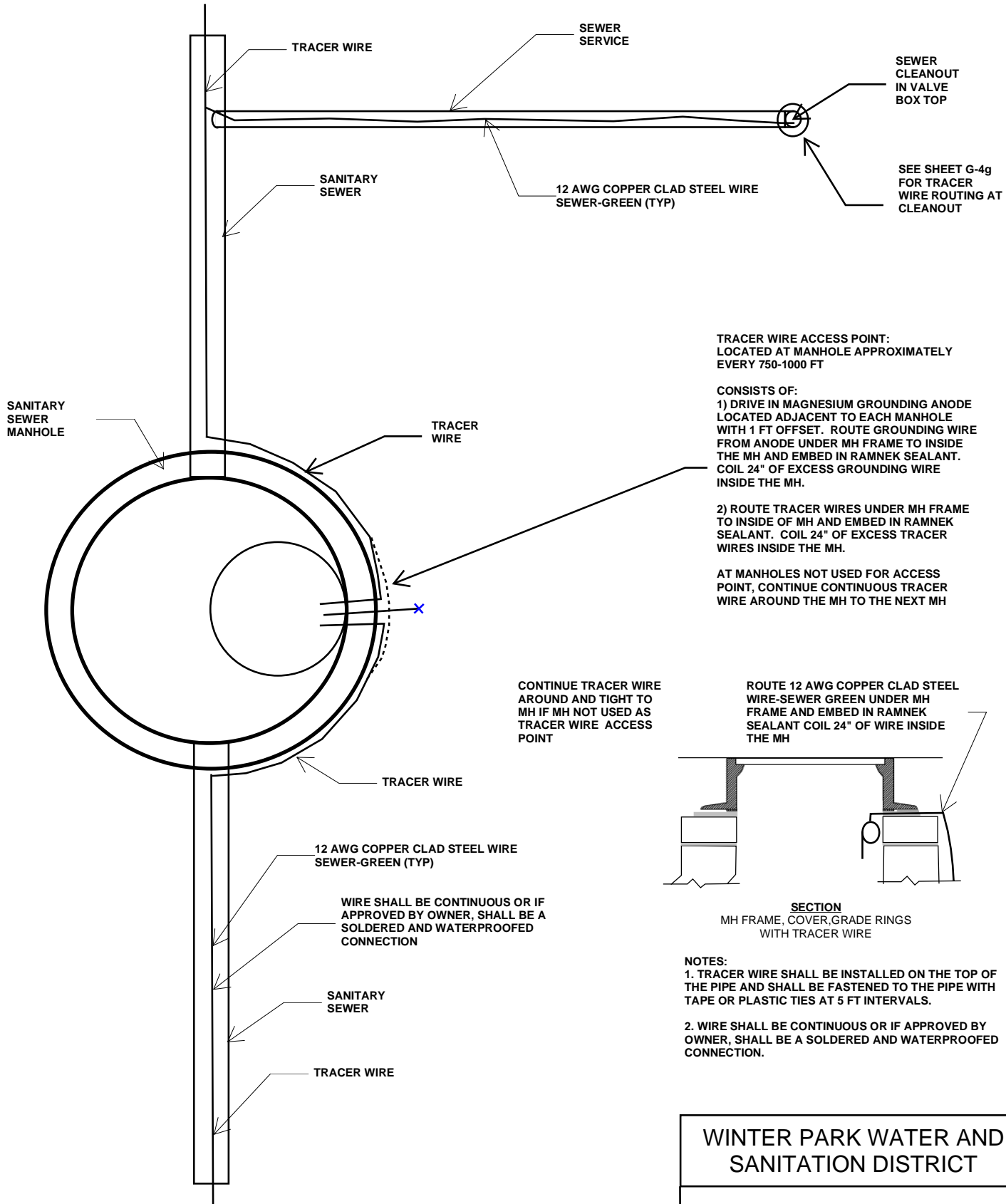

SEWER CLEANOUT IN VALVE BOX TOP

SEE SHEET G-4g FOR TRACER WIRE ROUTING AT CLEANOUT

TRACER WIRE ACCESS POINT:
LOCATED AT MANHOLE APPROXIMATELY EVERY 750-1000 FT

CONSISTS OF:
1) DRIVE IN MAGNESIUM GROUNDING ANODE LOCATED ADJACENT TO EACH MANHOLE WITH 1 FT OFFSET. ROUTE GROUNDING WIRE FROM ANODE UNDER MH FRAME TO INSIDE THE MH AND EMBED IN RAMNEK SEALANT. COIL 24" OF EXCESS GROUNDING WIRE INSIDE THE MH.

2) ROUTE TRACER WIRES UNDER MH FRAME TO INSIDE OF MH AND EMBED IN RAMNEK SEALANT. COIL 24" OF EXCESS TRACER WIRES INSIDE THE MH.

AT MANHOLES NOT USED FOR ACCESS POINT, CONTINUE CONTINUOUS TRACER WIRE AROUND THE MH TO THE NEXT MH

CONTINUE TRACER WIRE AROUND AND TIGHT TO MH IF MH NOT USED AS TRACER WIRE ACCESS POINT

ROUTE 12 AWG COPPER CLAD STEEL WIRE SEWER GREEN UNDER MH FRAME AND EMBED IN RAMNEK SEALANT COIL 24" OF WIRE INSIDE THE MH

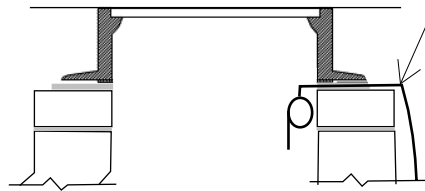

SECTION
MH FRAME, COVER, GRADE RINGS WITH TRACER WIRE

WIRE SHALL BE CONTINUOUS OR IF APPROVED BY OWNER, SHALL BE A SOLDERED AND WATERPROOFED CONNECTION

- NOTES:
1. TRACER WIRE SHALL BE INSTALLED ON THE TOP OF THE PIPE AND SHALL BE FASTENED TO THE PIPE WITH TAPE OR PLASTIC TIES AT 5 FT INTERVALS.
 2. WIRE SHALL BE CONTINUOUS OR IF APPROVED BY OWNER, SHALL BE A SOLDERED AND WATERPROOFED CONNECTION.

WINTER PARK WATER AND SANITATION DISTRICT

TRACER WIRE TEST STATION SEWER SYSTEM

DATE: 11/15/23

G-4i

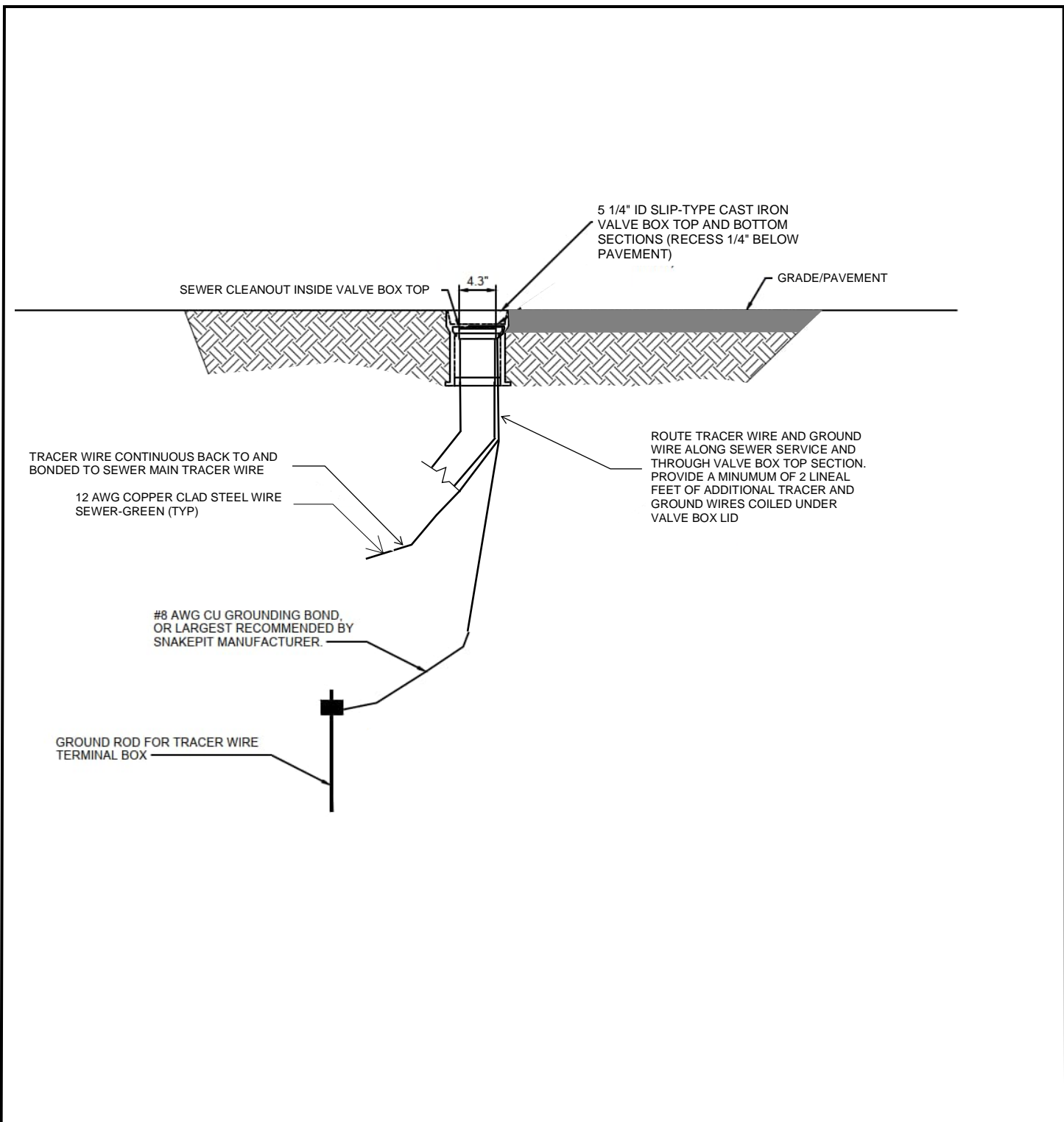

TRACER WIRE CONTINUOUS BACK TO AND BONDED TO SEWER MAIN TRACER WIRE

12 AWG COPPER CLAD STEEL WIRE SEWER-GREEN (TYP)

#8 AWG CU GROUNDING BOND, OR LARGEST RECOMMENDED BY SNAKEPIT MANUFACTURER.

GROUND ROD FOR TRACER WIRE TERMINAL BOX

5 1/4" ID SLIP-TYPE CAST IRON VALVE BOX TOP AND BOTTOM SECTIONS (RECESS 1/4" BELOW PAVEMENT)

GRADE/PAVEMENT

4.3"

SEWER CLEANOUT INSIDE VALVE BOX TOP

ROUTE TRACER WIRE AND GROUND WIRE ALONG SEWER SERVICE AND THROUGH VALVE BOX TOP SECTION. PROVIDE A MINIMUM OF 2 LINEAL FEET OF ADDITIONAL TRACER AND GROUND WIRES COILED UNDER VALVE BOX LID

NOTES:

1. LOCATE TRACER WIRE AND GROUND WIRES ON TOP OF SEWER SERVICE AND FASTEN TO PIPE WITH TAPE OR ZIP TIES AT 6 FT CENTERS.

2. SEWER TRACER WIRE: GREEN

WINTER PARK WATER AND SANITATION DISTRICT

TRACER WIRE ACCESS POINT SEWER SERVICE CLEANOUT

DATE: 11/15/23

G-4j

5/7/2015 11:12:59 AM, T:\PROJECTS\6844633_WP_SD_NEW_GENERAL_SE\SUB_00\9.0_CAD\STANDARDDETAILS\2009 REVISIONS\DETAILW-1.DWG, CHAVEZ, JULIAN

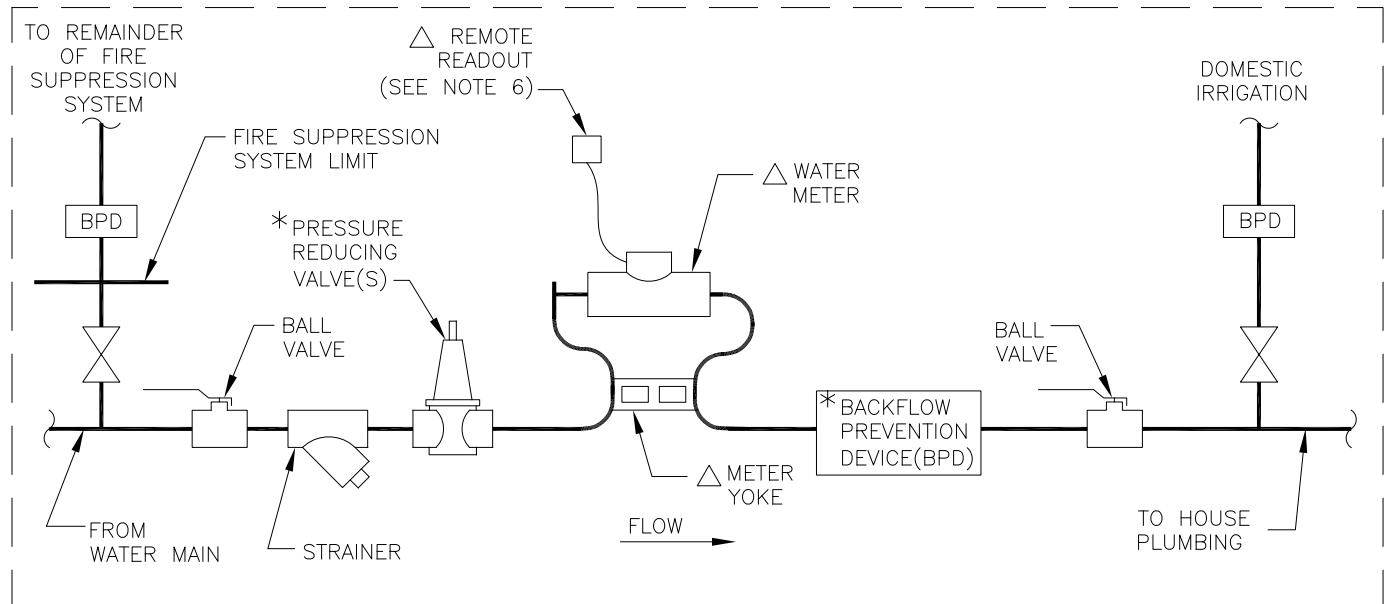

* EQUIPMENT FURNISHED BY DISTRICT;
OWNED AND MAINTAINED BY PROPERTY OWNER.

△ EQUIPMENT FURNISHED, OWNED AND
MAINTAINED BY DISTRICT.

NOTES

1. VALVES SHALL BE FULL-PORT VALVES.
2. LOCATION OF WATER METER SERVICE EQUIPMENT AND REMOTE READOUT SHALL BE APPROVED BY THE DISTRICT PRIOR TO CONSTRUCTION.
3. WATER SERVICE EQUIPMENT SHALL BE LOCATED IN A HEATED SPACE, WITH REASONABLE SPACE FOR SERVICE OF EQUIPMENT.
4. METER SHALL BE SET IN METER YOKE. CONTRACTOR SHALL COORDINATE WITH DISTRICT SO DISTRICT CAN FURNISH THE PROPER METER YOKE FOR THE INSTALLATION.
5. METER MUST BE MOUNTED WITH REGISTER UPRIGHT AND METER HORIZONTAL, AND IN ACCORDANCE WITH MANUFACTURERS INSTRUCTIONS.
6. REMOTE READOUT LOCATION MUST BE APPROVED BY THE DISTRICT STAFF PRIOR TO INSTALLATION. LOCATION OF REMOTE READOUT SHALL BE VISIBLE FROM THE STREET AND SHALL BE ACCESSIBLE YEAR-ROUND. REMOTE READOUT SHALL NOT BE LOCATED UNDER EAVE WHERE SNOW OR ICE CAN INTERFERE WITH EQUIPMENT OPERATION OR WOULD LIMIT ACCESS.
7. BACKFLOW PREVENTION DEVICE MUST BE INSTALLED IN ACCORDANCE WITH MANUFACTURERS RECOMMENDATIONS.
8. TYPE OF BACKFLOW PREVENTION DEVICE WILL BE DETERMINED BY THE DISTRICT BASED ON THE THE BACKFLOW PREVENTION NEED. IF A REDUCED PRESSURE PRINCIPAL TYPE DEVICE IS REQUIRED, IT MUST BE LOCATED WHERE THE DEVICE CAN BE PLUMBED TO A DRAIN.
9. SOME INSTALLATIONS MAY REQUIRE TWO PRESSURE REDUCING VALVES IN SERIES.
10. IF WATER SERVICE LOCATION IS IN CRAWL SPACE, EQUIPMENT SHALL BE LOCATED WITHIN 3 FEET OF THE CRAWL SPACE ENTRANCE.
11. BACKFLOW PREVENTION DEVICES MUST BE INSPECTED AND TESTED BY CERTIFIED SERVICE PERSONNEL ANNUALLY AT OWNERS EXPENSE.

WINTER PARK WATER AND
SANITATION DISTRICT

**WATER SERVICE
INSTALLATION
SINGLE FAMILY RESIDENCE**

DATE: 5/6/2015

W-1

5/7/2015 11:13:40 AM, T:\PROJECTS\6844633_WP_SD_NEW_GENERAL_SE\SUB_00\9_0_CAD\STANDARDDETAILS\2009 REVISIONS\DETAILW-2.DWG, CHAVEZ, JULIAN

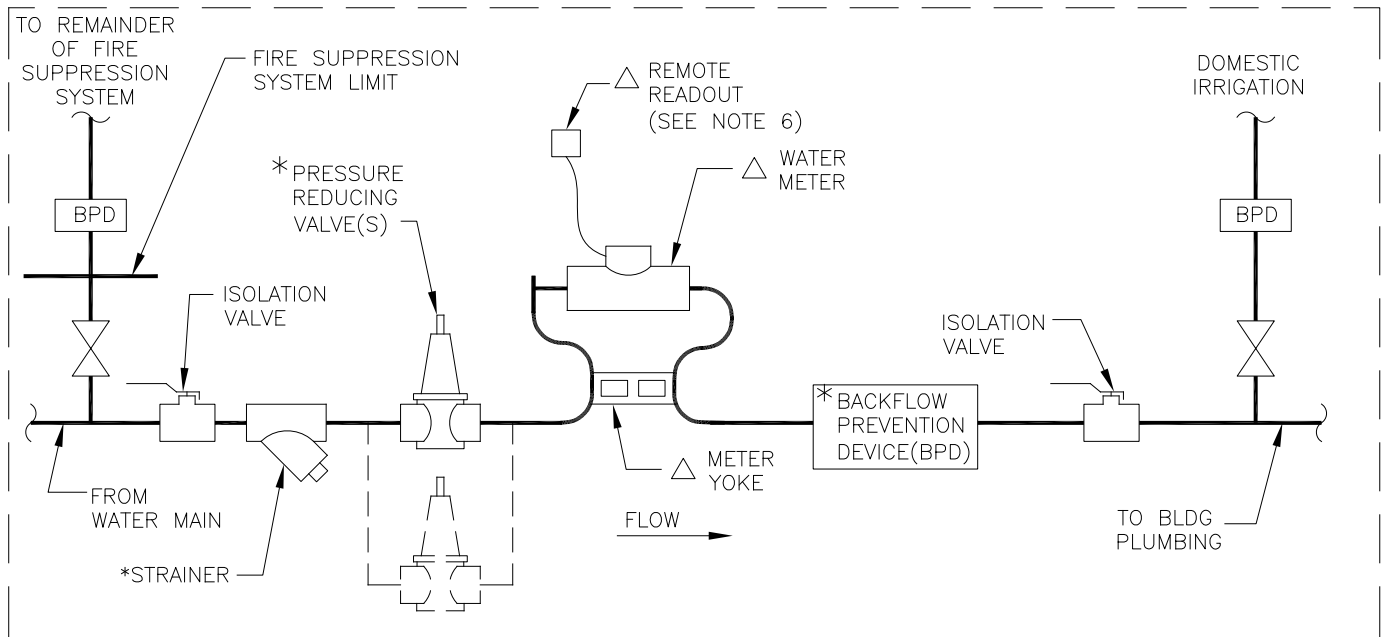

* EQUIPMENT FURNISHED BY DISTRICT; OWNED AND MAINTAINED BY PROPERTY OWNER.

△ EQUIPMENT FURNISHED, OWNED AND MAINTAINED BY DISTRICT.

NOTES

1. ISOLATION VALVE SHALL BE FULL-PORT BALL VALVE.
2. LOCATION OF WATER METER SERVICE EQUIPMENT AND REMOTE READOUT SHALL BE APPROVED BY THE DISTRICT PRIOR TO CONSTRUCTION.
3. WATER SERVICE EQUIPMENT SHALL BE LOCATED IN A HEATED SPACE, WITH REASONABLE SPACE FOR SERVICE OF EQUIPMENT.
4. METER SHALL BE SET IN METER YOKE. CONTRACTOR SHALL COORDINATE WITH DISTRICT SO DISTRICT CAN FURNISH THE PROPER METER YOKE FOR THE INSTALLATION.
5. METER MUST BE MOUNTED WITH REGISTER UPRIGHT AND METER HORIZONTAL, AND IN ACCORDANCE WITH MANUFACTURERS INSTRUCTIONS.
6. REMOTE READOUT LOCATION MUST BE APPROVED BY THE DISTRICT STAFF PRIOR TO INSTALLATION. LOCATION OF REMOTE READOUT SHALL BE VISIBLE FROM THE STREET AND SHALL BE ACCESSIBLE YEAR-ROUND. REMOTE READOUT SHALL NOT BE LOCATED UNDER EAVE WHERE SNOW OR ICE CAN INTERFERE WITH EQUIPMENT OPERATION OR WOULD LIMIT ACCESS.
7. BACKFLOW PREVENTION DEVICE MUST BE INSTALLED IN ACCORDANCE WITH MANUFACTURERS RECOMMENDATIONS.
8. TYPE OF BACKFLOW PREVENTION DEVICE WILL BE DETERMINED BY THE DISTRICT BASED ON THE THE BACKFLOW PREVENTION NEED. IF A REDUCED PRESSURE PRINCIPAL TYPE DEVICE IS REQUIRED, IT MUST BE LOCATED WHERE THE DEVICE CAN BE PLUMBED TO A DRAIN.
9. 1-1/2" AND 2" SERVICES MAY REQUIRE MULTIPLE PRV'S IN PARALLEL OR SERIES TO PROVIDE PROPER PRESSURE REDUCTION OVER VARYING FLOW RANGES.
10. IF WATER SERVICE LOCATION IS IN CRAWL SPACE, EQUIPMENT SHALL BE LOCATED WITHIN 3 FEET OF THE CRAWL SPACE ENTRANCE.
11. BACKFLOW PREVENTION DEVICES MUST BE INSPECTED AND TESTED BY CERTIFIED SERVICE PERSONNEL ANNUALLY AT OWNERS EXPENSE.
12. PLANS FOR MULTI-FAMILY AND/OR COMMERCIAL DEVELOPMENT SERVICE INSTALLATIONS SHALL BE SUBMITTED TO THE DISTRICT PRIOR TO CONSTRUCTION TO VERIFY PROPER INSPECTION AND SERVICE ACCESS IS PROVIDED.

CONTACT DISTRICT FOR REQUIREMENTS FOR WATER SERVICE INSTALLATIONS LARGER THAN 2-INCHES.

WINTER PARK WATER AND SANITATION DISTRICT	
WATER SERVICE INSTALLATION MULTI-FAMILY OR COMMERCIAL DEVELOPMENT	
DATE: 5/6/2015	W-2

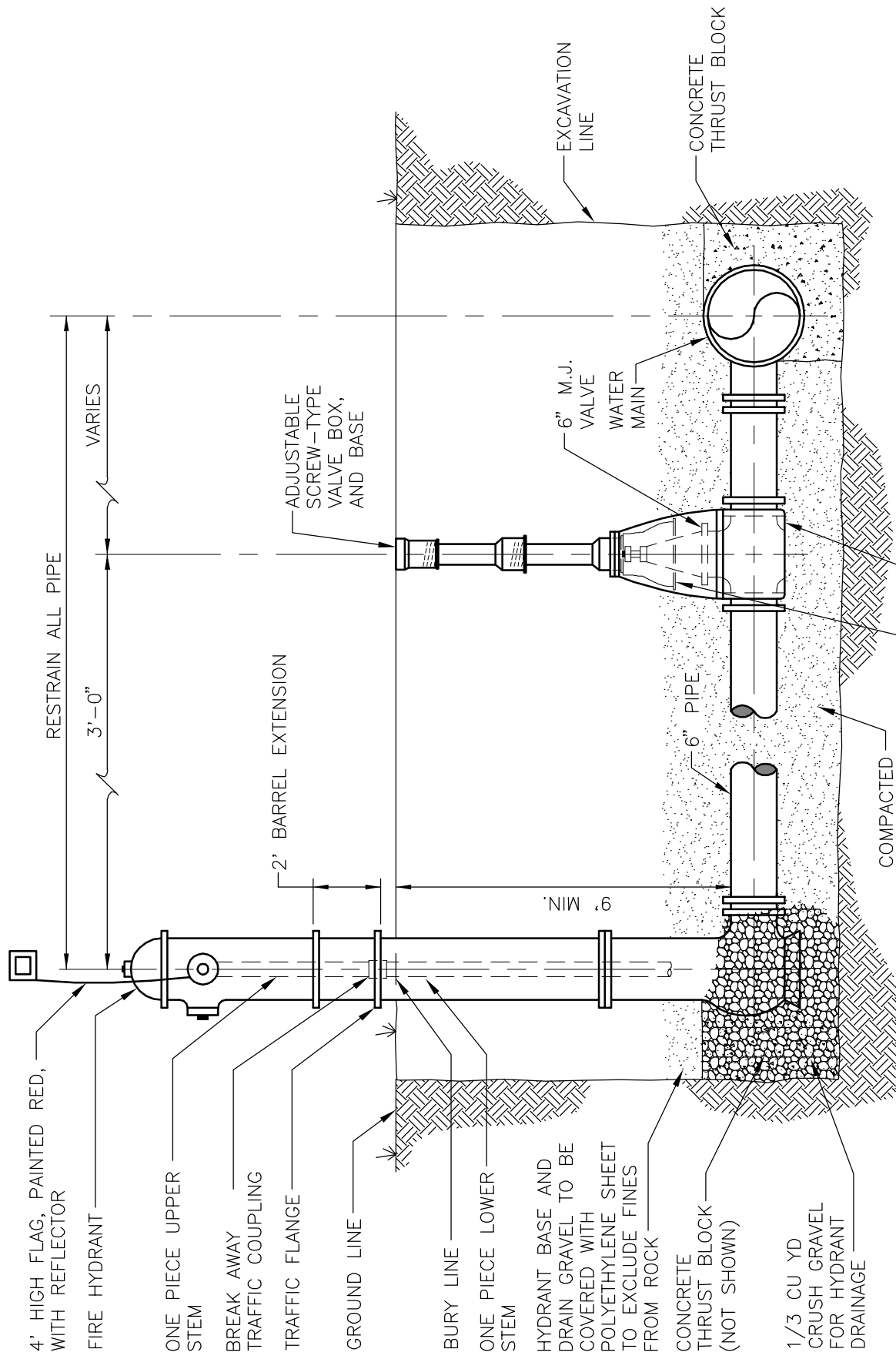

NOTE

1. FIRE HYDRANT SHALL BE MUELLER SUPER CENTURIAN, MOUNTAIN STANDARD, MOUNTAIN BURY WITH ONE PIECE UPPER STEM AND ONE PIECE (9' MIN) LOWER STEM.
2. BACKFILL SHALL BE COMPACTED IN MAXIMUM 6" LIFTS. IF HYDRANT IS NOT PLUMB, CONTRACTOR SHALL RESET.

WINTER PARK WATER AND SANITATION DISTRICT	
FIRE HYDRANT SETTING DETAIL	
DATE: 2/23/2009	W-3

2/24/2009 12:59:17 PM:T:\PROJECTS\GENERAL_SE\SUB_00\9.0_CAD\STANDARDDETAILS\2009 REVISIONS\DETAILW-4.DWG,JIM_HEALY

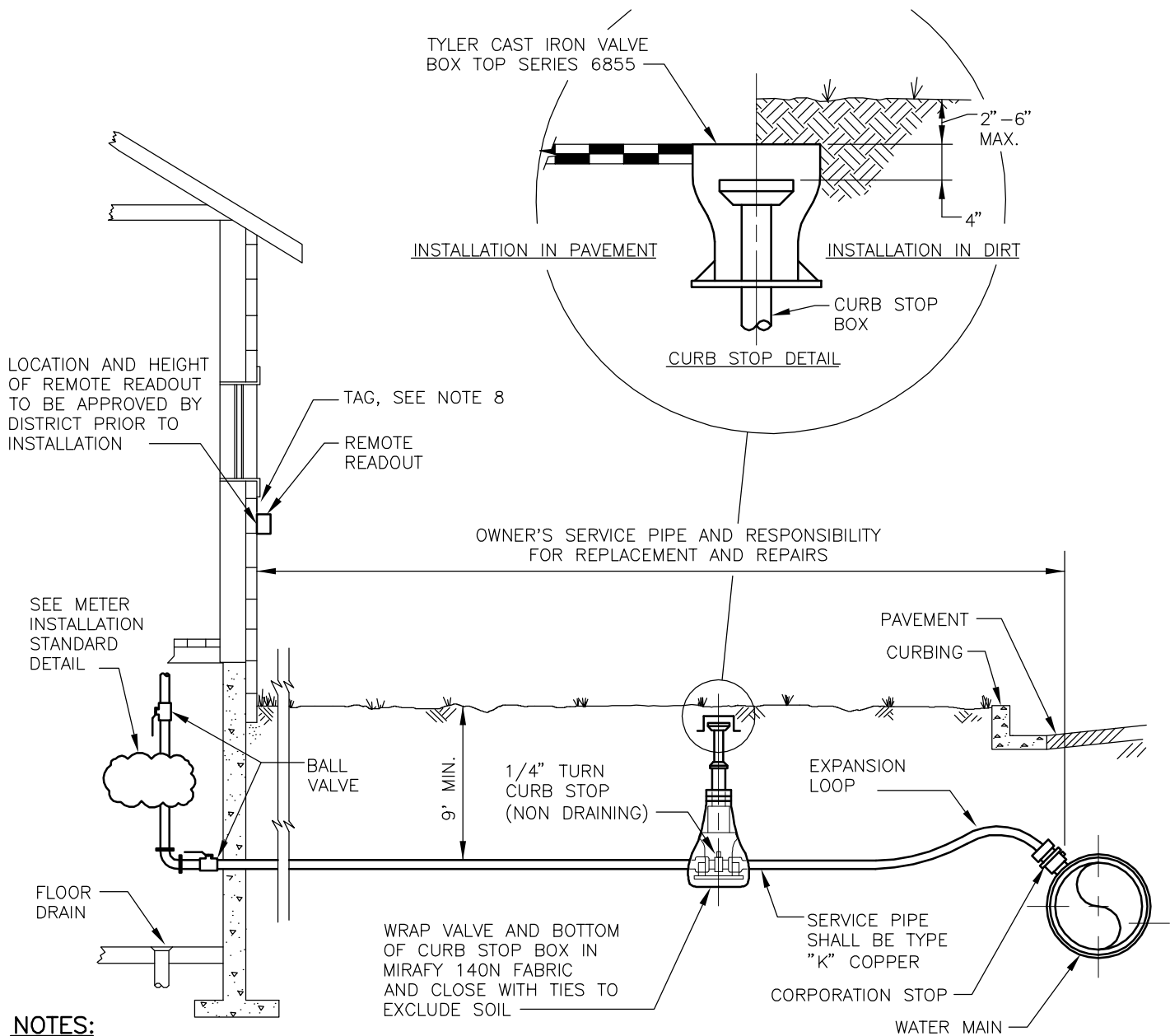

NOTES:

1. PLACE CURB STOP ON PRIVATE PROPERTY WITHIN 15 FT. OF PROPERTY LINE. CURB STOP SHALL NOT BE INSTALLED WITHIN A DITCH OR DRAINAGE. THE SITE DESIGN SHALL BE COMPLETED SUCH THAT THESE CONDITIONS CAN BE VERIFIED. LOCATION TO BE APPROVED BY THE DISTRICT PRIOR TO INSTALLATION. CURB STOP MUST BE LOCATED AT A SITE THAT IS ACCESSIBLE AT ALL TIMES, AND MUST NOT BE SUBJECT TO BURIAL UNDER SNOW STORAGE.
2. SERVICE PIPE SHALL BE INSTALLED WITH 6" OF COMPACTED BEDDING ON SIDES AND BOTTOM OF PIPE AND 12" ON TOP OF OF THE PIPE.
3. CURB STOP BOX SHALL BE CAST IRON AND COVER STAMPED "WATER". CURB STOP BOX SHALL BE INSTALLED STRAIGHT AND VERTICAL.
4. WITH INSTALLATION OF MULTIPLE CURB BOXES, CURB BOXES MUST BE SEPARATED BY 12-18".
5. INDOOR METER SHALL BE PLACED IN LOCATIONS WITH FLOOR DRAIN NEARBY.
6. NO BENDS, FITTINGS, CONNECTIONS, OR CHANGES IN PIPE SIZE PERMITTED BETWEEN TAP AND METER OUTLET VALVE, EXCEPT AS SHOWN.
7. CORPORATION STOP, CURB STOP AND SERVICE LINE SHALL BE THE SAME SIZE FROM MAIN TO THE SHUTOFF VALVE INSIDE THE BUILDING.
8. FOR MULTI-FAMILY BUILDINGS, PROVIDE ADDRESS AND UNIT NUMBER ON A BRASS TAG. THE TAG SHALL BE MOUNTED IMMEDIATELY ADJACENT TO THE REMOTE READOUT.

WINTER PARK WATER AND SANITATION DISTRICT	
SERVICE LINE, STOP BOX AND INSIDE METER INSTALLATION FOR SINGLE FAMILY RESIDENCE	
DATE: 2/23/2009	W-4

3/24/2009 1:08:01 PM, T:\PROJECTS\6844633_WP_SD_NEW_GENERAL_SE\SUB_00\9.0_CAD\STANDARDDETAILS\2009 REVISIONS\DETAILW-5.DWG-JIM_HEALY

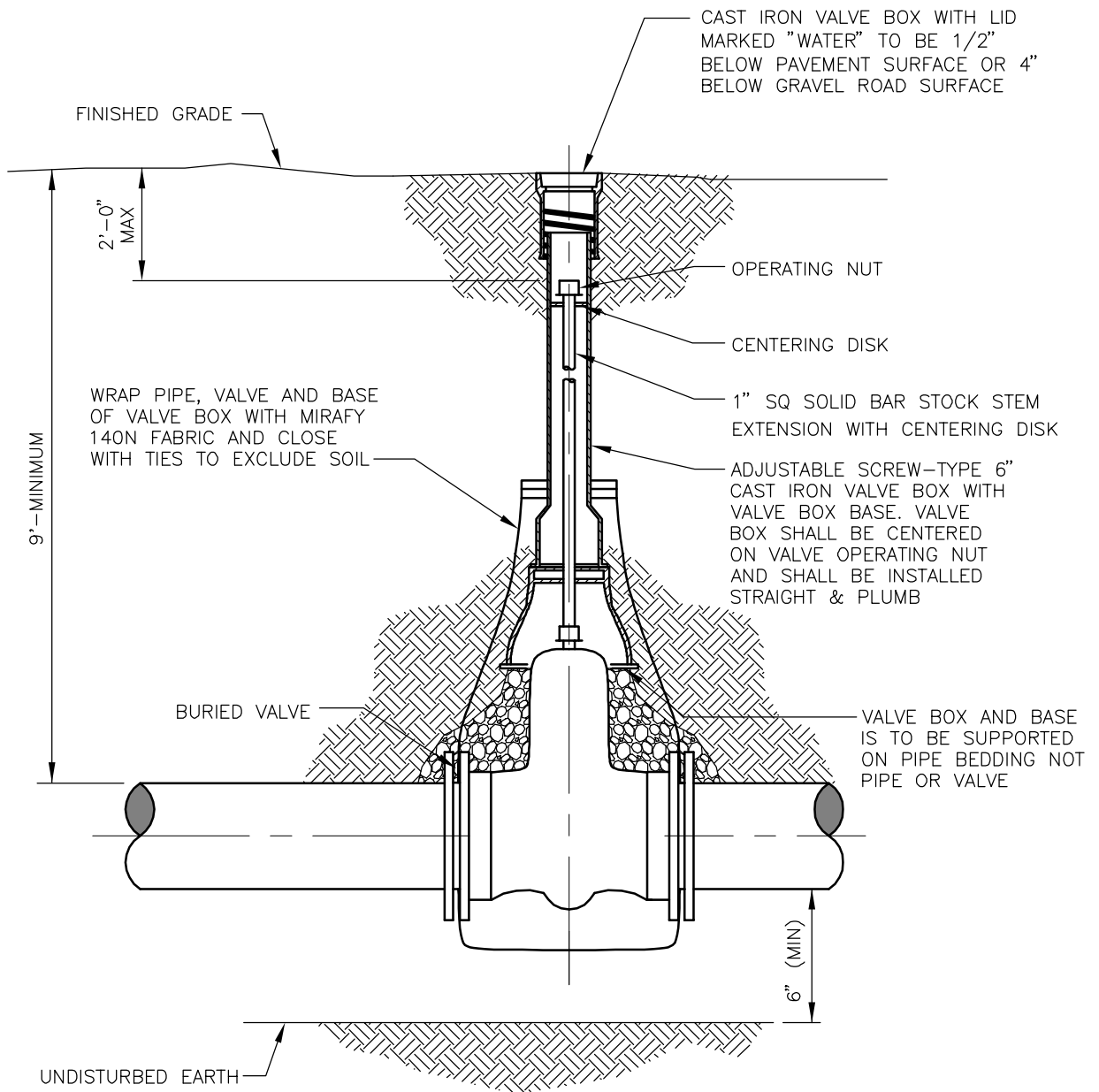

NOTES:

1. BACKFILL SHALL BE COMPACTED IN MAXIMUM 6" LIFTS. IF VALVE BOX IS NOT PLUMB, CONTRACTOR SHALL RESET.

WINTER PARK WATER AND SANITATION DISTRICT	
VALVE BOX INSTALLATION	
DATE: 3/24/2009	W-5

2/24/2009 1:01:57 PM.T:\PROJECTS\6844633_WP_SD_NEW_GENERAL_SE\SUB_00\9_0_CAD_STANDARDDETAILS\2009 REVISIONS\DETAILW-6.DWG_JIM_HEALY

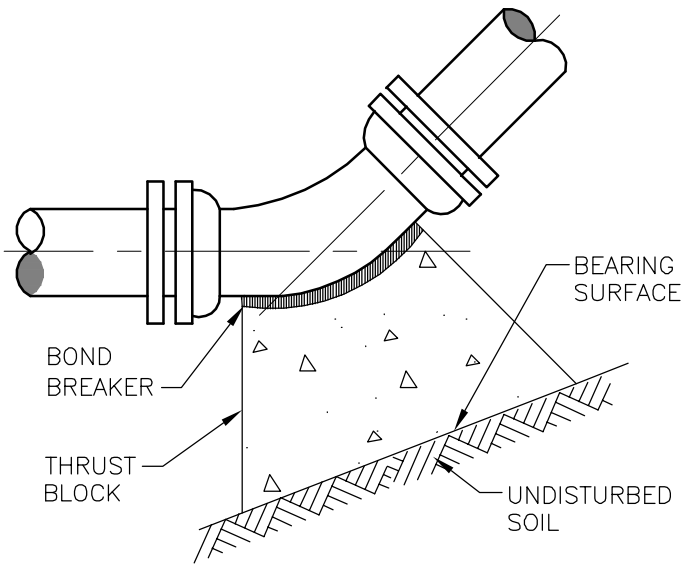

11¼°, 22½°, 45° AND 90° BENDS

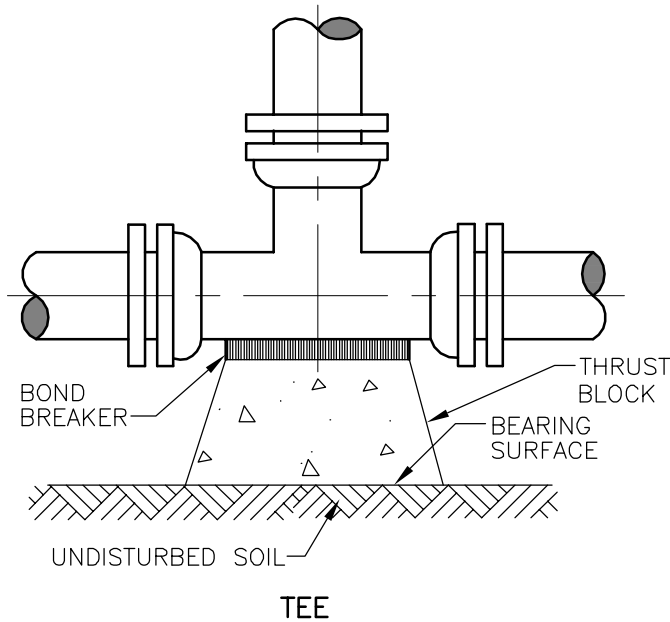
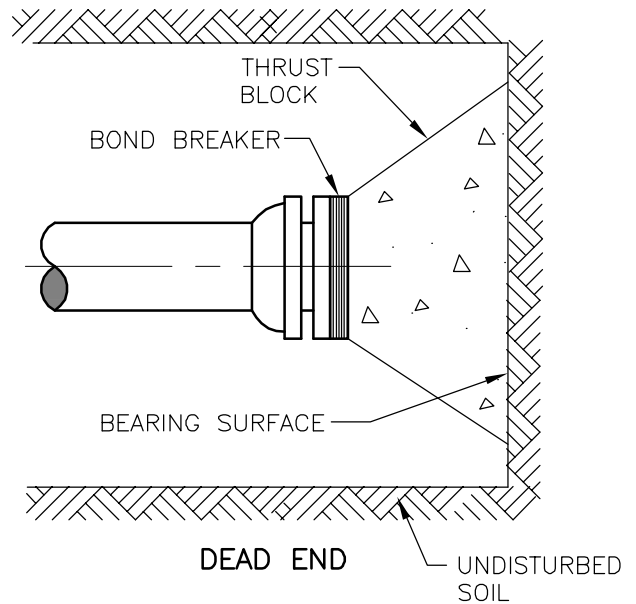

TEE

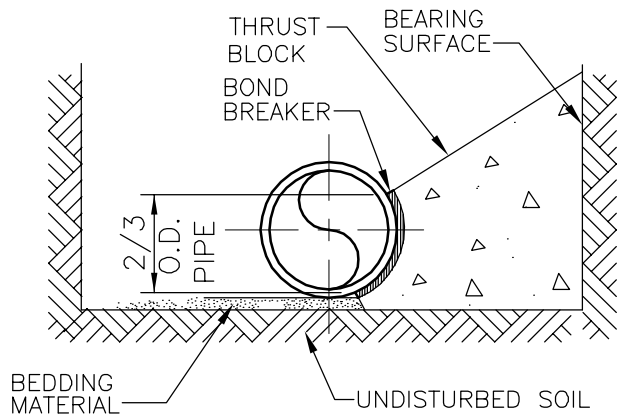

TYPICAL CROSS SECTION

NOTES

1. BEARING SURFACES SHOWN IN CHART ARE MINIMUMS BASED ON AWWA M41.
2. BASED ON 150 AND 250 PSI INTERNAL PIPE PRESSURE.
3. BASED ON 2000 PSF SOIL BEARING CAPACITY. VERIFY ACTUAL FIELD CONDITIONS
4. SAFETY FACTOR = 1.5.
5. CONCRETE MUST HAVE A MINIMUM COMPRESSIVE STRENGTH OF 4000psi AFTER 28 DAYS. CONCRETE MUST BE COMPLETELY BATCHED BEFORE PLACING CONCRETE INTO THE THRUST BLOCK FORMS.
6. ALL THRUST BLOCKS MUST MEET MINIMUM CONCRETE CURE TIMES BEFORE BACKFILL AND PRESSURIZATION OF THE PIPE. SEE WATER MAIN SPECIFICATION FOR DETAILED REQUIREMENTS.
7. ALL JOINTS SHALL BE RESTRAINED WITH MEGALUG AND THRUST BLOCKS.
8. VERIFY DESIGN PRESSURE FOR TABLE REPRESENTS ACTUAL CONDITIONS.

MINIMUM BEARING SURFACE AREA (IN SQUARE FEET) 150 PSI INTERNAL PRESSURE (225 PSI TEST PRESSURE)					
SIZE OF PIPE	BENDS				TEE OR DEAD END
	11¼°	22½°	45°	90°	
6"	1	2	5	9	13
8"	2	4	8	15	22
12"	5	9	18	33	46

MINIMUM BEARING SURFACE AREA (IN SQUARE FEET) 250 PSI INTERNAL PRESSURE (375 PSI TEST PRESSURE)					
SIZE OF PIPE	BENDS				TEE OR DEAD END
	11¼°	22½°	45°	90°	
6"	2	4	8	15	21
8"	4	7	14	26	36
12"	8	15	29	54	77

WINTER PARK WATER AND SANITATION DISTRICT

CONCRETE KICKBLOCKS BEARING SURFACES AND INSTALLATION

DATE: 2/23/2009

W-6

2/24/2009 1:04:05 PM, T:\PROJECTS\6844633_WP_SD_NEW_GENERAL_SE\SUB_00\9.0_CAD\STANDARDDETAILS\2009 REVISIONS\DETAILW-7.DWG-JIM_HEALY

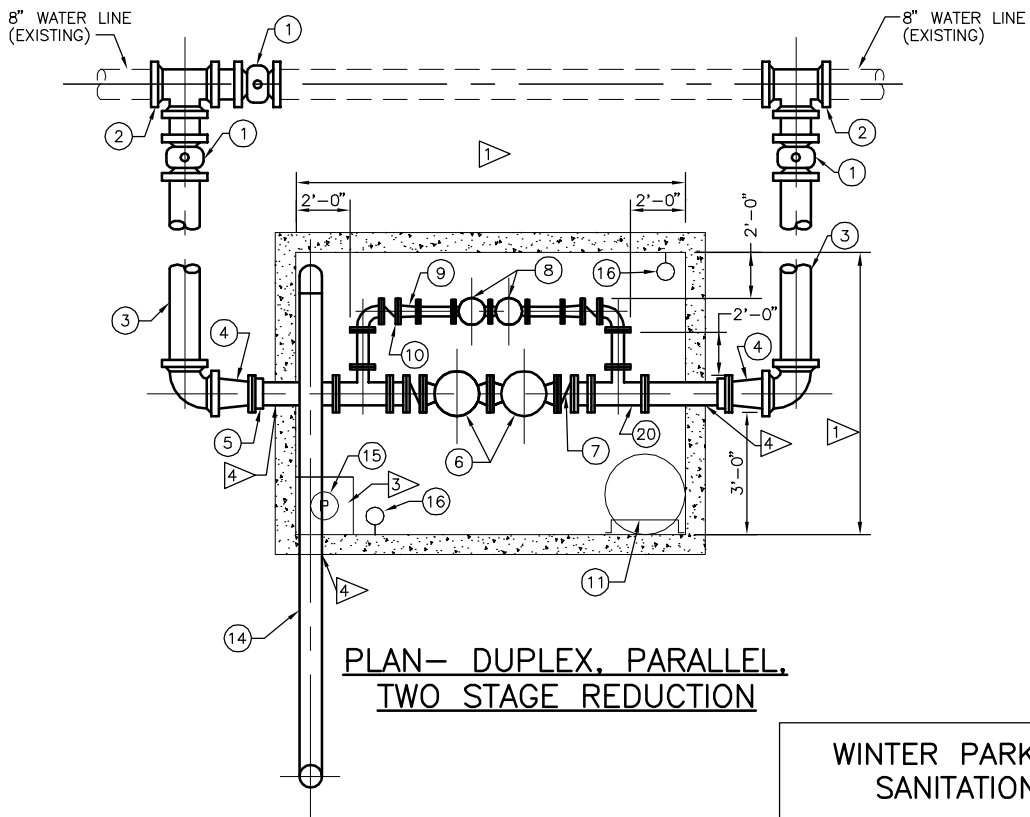
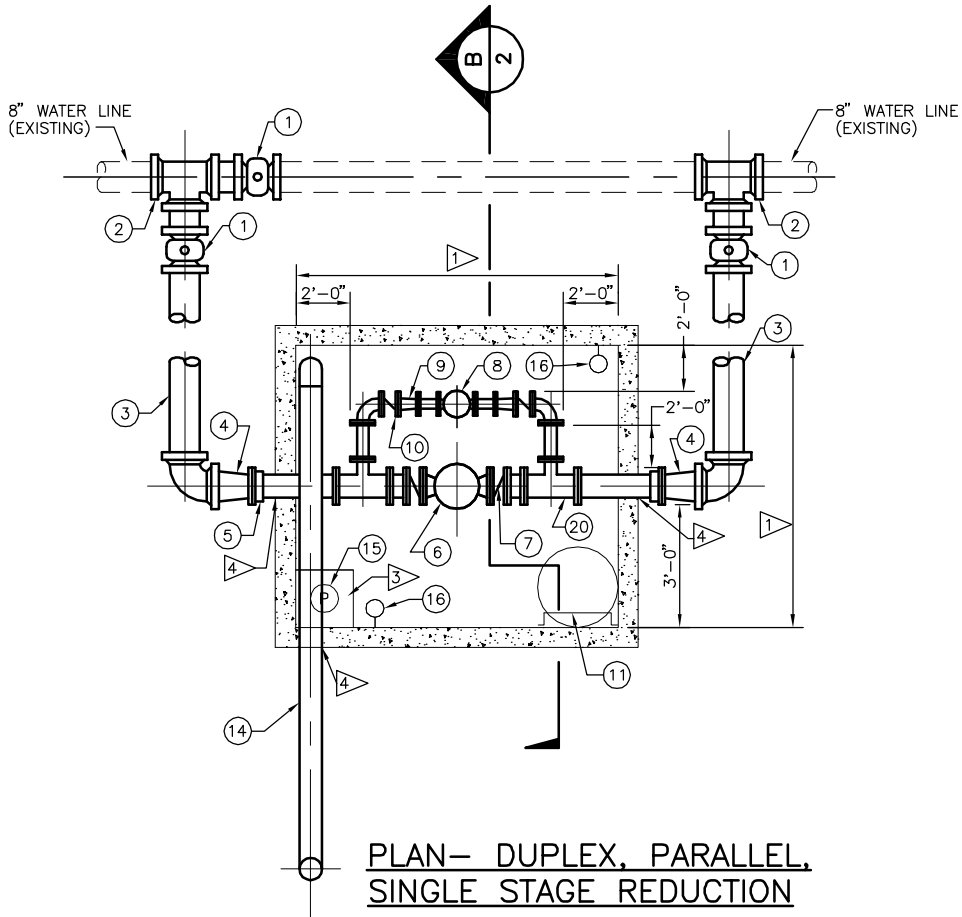

WINTER PARK WATER AND
SANITATION DISTRICT

PRV VAULT
PLAN VIEW

DATE: 2/23/2009 **Sheet 1** W-7

2/24/2009 1:05:27 PM, T:\PROJECTS\6844633_WP_SD_NEW_GENERAL_SE\SUB_00\9_0_CAD\STANDARDDETAILS\2009 REVISIONS\DETAILW-7.DWG-JIM_HEALY

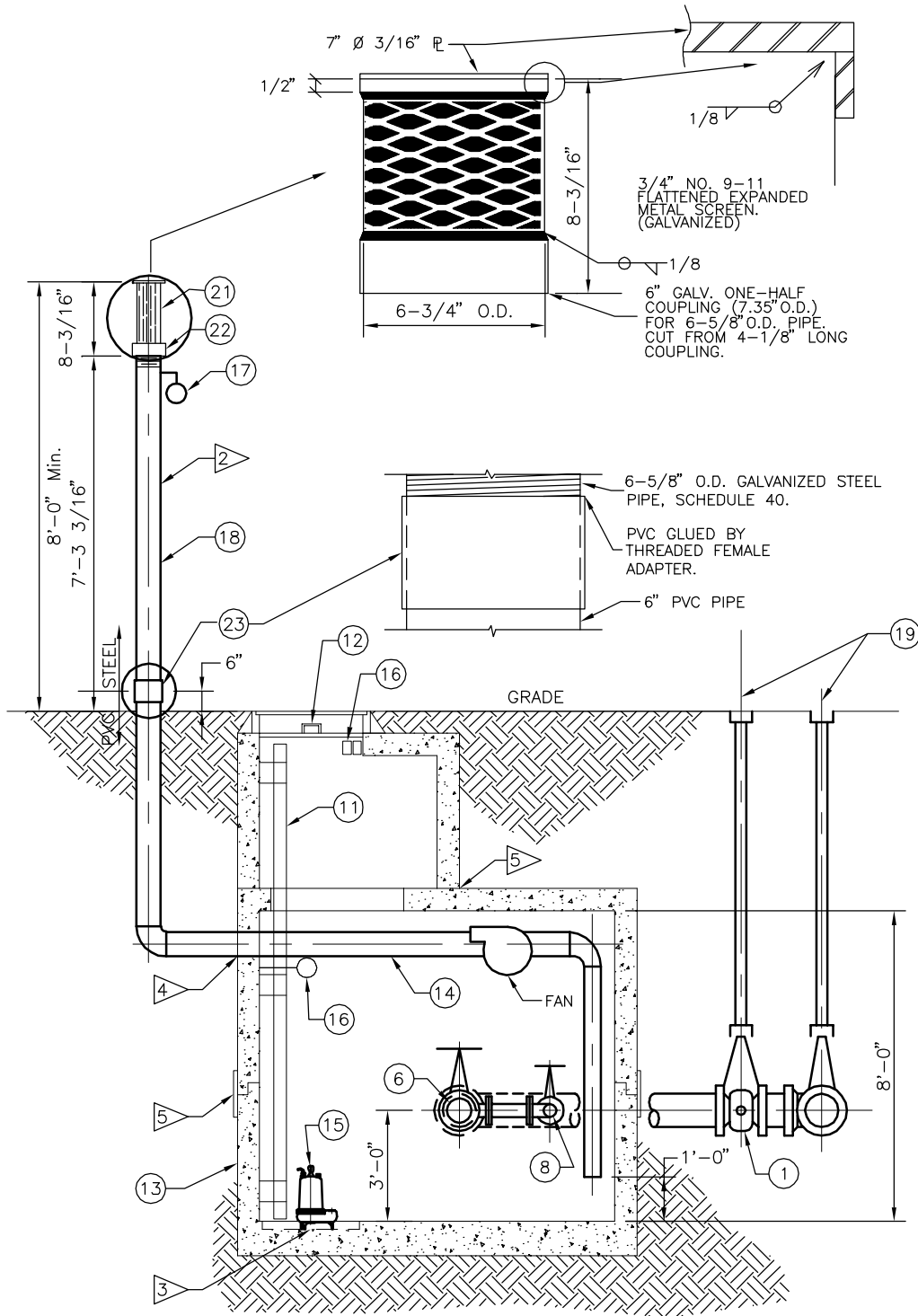

WINTER PARK WATER AND SANITATION DISTRICT

PRV VAULT SECTION

DATE: 2/23/2009 Sheet 2 W-7

GENERAL NOTES:

1. NOTE ALL FITTINGS, PIPE AND EQUIPMENT ARE LABELED IF TYPICAL.
2. ALL PIPING INSIDE VAULT SHALL BE EPOXY COATED PER TMEMIC SERIES OR APPROVED EQUAL.
3. VALVES 2" AND SMALLER SHALL BE SS BALL VALVES.
4. PIPE AND CONTROL VALVE SIZING AND OPERATING PRESSURE SHALL BE APPROVED BY WPWS.
5. ALL PIPE INSIDE VAULT SHALL BE FLANGED OR RESTRAINED.
6. ALL BURIED PIPE SHALL BE MECHANICAL JOINT PIPE.
7. ALL PRV VAULTS SHALL BE PROVIDED WITH 120 V POWER, LIGHTS, SWITCHED EXHAUST FAN, ELECTRICAL RECEPTICLES, SUMP PUMP, WATER ON FLOOR SWITCH, AND EXTERIOR ALARM LIGHT.
8. ALL WORK SHALL BE IN ACCORDANCE WITH THE DISTRICT RULES AND REGULATIONS, THE NEC, AND ANY OTHER APPLICABLE REGULATIONS.

CONSTRUCTION NOTES:

- 1 ▷ VAULT DIMENSIONS AS REQUIRED TO PROVIDE FOR EQUIPMENT AND CLEARANCES SHOWN.
- 2 ▷ VENT PIPE TO BE LOCATED IN FIELD AT THE NEAREST INTERSECTION OF THE STREET PROPERTY LINE AND THE SIDE LOT LINE. LOCATION TO BE APPROVED BY WPWS. FOR RESIDENTIAL INSTALLATIONS, SEE DENVER WATER DRAWING #40.
- 3 ▷ 4" DEPRESSION IN FLOOR FOR SUMP (18" SQUARE).
- 4 ▷ FIELD LOCATE AND CORE DRILL OPENINGS FOR PIPE AND DUCTS. SEAL ANNULUS WITH LINKSEAL-TYPE WALL PENETRATION SEALS AT INSIDE AND OUTSIDE ALL SURFACE. LINKSEAL SHALL BE INSTALLED TO BE TIGHTENED FROM INSIDE THE VAULT. CAST IN PLACE OPENINGS SHALL BE FURNISHED WITH EPOXY COATED WALL SLEEVES.
- 5 ▷ ALL FIELD JOINTS SHALL BE SEALED WITH 2 STRIPS OF RAMNEK. EXTERIOR WALL SHALL BE PRIMED WITH ASPHALT TACK COAT AND WRAPPED WITH 12" CONWRAP.

WINTER PARK WATER AND
SANITATION DISTRICT

**PRV VAULT
GENERAL AND FLAG NOTES**

DATE: 2/23/2009 **Sheet 3 W-7**

EQUIPMENT NOTES:

- ① RESILIENT SEAT GATE VALVE, VALVE BOX AND VALVE STEM EXTENSION.
- ② MJ TEE AND SWIVEL COUPLING ANCHOR.
- ③ 8" DIP PIPING TO VAULT.
- ④ 8" x 6" MJ REDUCER.
- ⑤ 6" FLG x PE PIPE SPOOL WITH RESTRAINT.
- ⑥ 6" PRESSURE REDUCING VALVE CLA-VAL 90-01 ABCSKC, 150# FLANGED (2 VALVES IN SERIES MAY BE REQUIRED DEPENDENT ON PRESSURES - CONSULT WPWS).
- ⑦ 6" BFV WITH GEAR OPERATOR.
- ⑧ 2-1/2" PRESSURE REDUCING VALVE CLA-VAL 90-01 ABCSKC, 150# FLANGED (2 VALVES IN SERIES MAY BE REQUIRED DEPENDENT ON PRESSURES CONSULT WPWS).
- ⑨ 3" x 2-1/2" REDUCER.
- ⑩ 3" BFV WITH LEVER ACTUATOR.
- ⑪ STEEL LADDER GALVANIZED WITH 3/4" STOPS @ 12" O.C. AND 2-1/2" x 3/8" RAILS AND ANCHOR LEGS.
- ⑫ 36" MH WITH 24" MH INSERT, HEAVY DUTY RATING, FROST PROOF.
- ⑬ CAST-IN-PLACE/PRE-CAST VAULT SHALL BE DESIGNED FOR BURY LOADS AND ALSO PROVIDE FOR BOUYANT FORCES FOR HIGH GROUND WATER WITH MINIMUM REQUIREMENT FOR PRECAST MEETING ASTM C-857, C-858, ACI 318-89 HS 20 LOADING.
- ⑭ 6" DIAMETER SCHEDULE 40 PVC PIPE WITH GLUED JOINTS.
- ⑮ SUBMERSIBLE PUMP ACTIVATED BY PRESSURE SWITCH. WITH (NOT SHOWN) DISCHARGE TO DAYLIGHT AS APPROVED BY WPWS.
- ⑯ SUBMERSIBLE LIGHT FIXTURES (2) AND RECEPTACLES (2) SHALL BE PROVIDED; 7' AFF. LIGHTS TO BE OPERATED BY SWITCH LOCATED AT VAULT ENTRANCE. ADDITIONAL RECEPTACLE TO BE PROVIDED AT VAULT ENTRANCE.
- ⑰ WATER ON FLOOR SWITCH SHALL ACTIVATE ALARM LIGHT MOUNTED ON VENT PIPE.
- ⑱ 6-5/8" O.D. SCHEDULE 40 GALVANIZED STEEL VENT PIPE WITH THREADED JOINTS.
- ⑲ VALVE BOX WITH HEAVYWEIGHT ONE PIECE STEM EXTENSION AND ONE PIECE RISER.
- ⑳ 6" x 6" x 3" TEE
- ㉑ FABRICATED VENT SCREEN
- ㉒ THREADED END ON VENT PIPE
- ㉓ BREAKAWAY COUPLING

WINTER PARK WATER AND
SANITATION DISTRICT

PRV VAULT
EQUIPMENT NOTES

DATE: 2/23/2009 **Sheet 4 W-7**

7/31/2015 2:53:49 PM, I:\PROJECTS\6844633_WP_SD_NEW_GENERAL_SE\SUB_00\9.0_CAD\STANDARDDETAILS\2009 REVISIONS\DETAILW-8.DWG, CHAVEZ, JULIAN

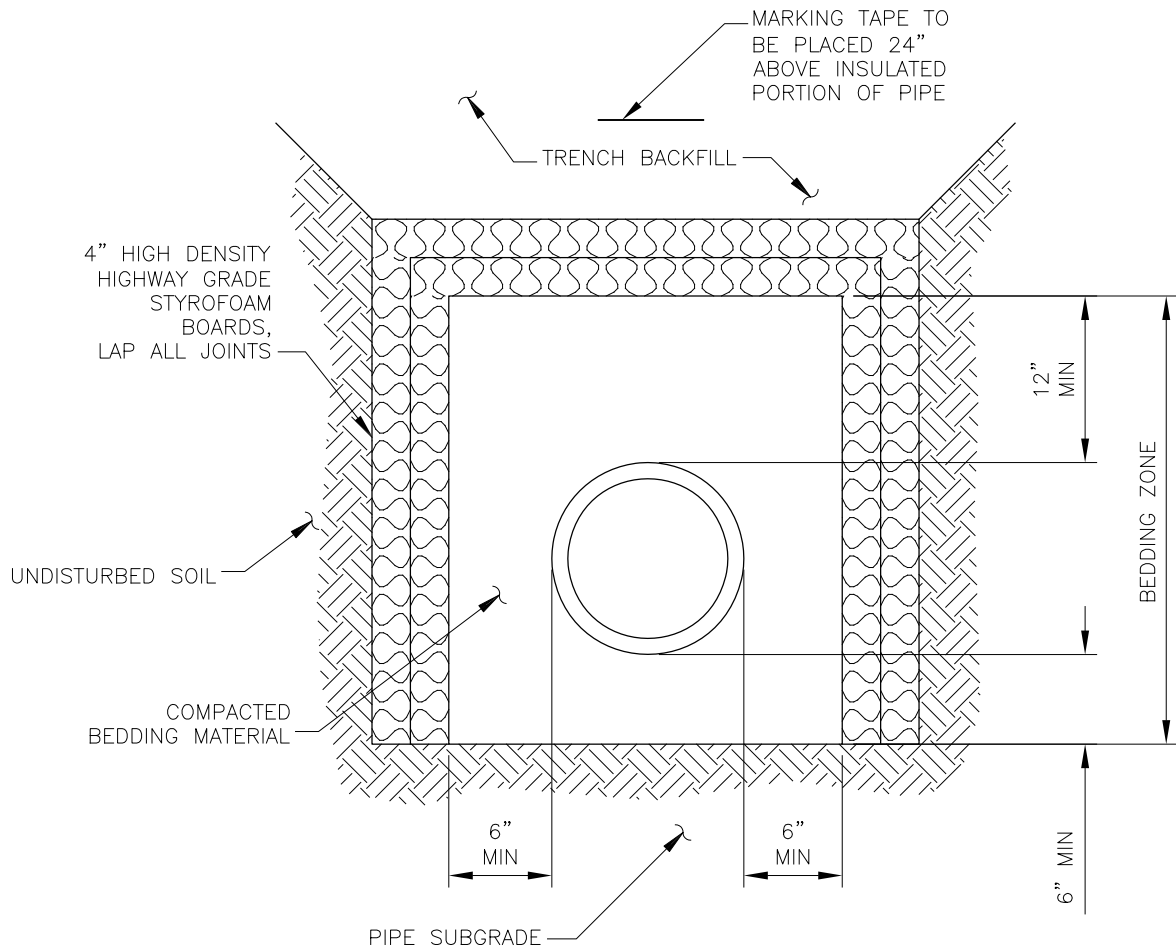

NOTES

1. INSULATION REQUIRED FOR CONDITIONS OF LESS THAN 9' DEPTH OF BURY TO TOP OF PIPE OR LESS THAN 3 FEET SEPARATION FROM CULVERTS.
2. MAINTAIN CLEARANCE BETWEEN ALL PARTS OF THE PIPE AND INSULATION WITH BEDDING.
3. EXERCISE CARE IN FITTING BOARDS TO PERMIT NOT MORE THAN 1/4" SIZE GAPS.

WATER PIPE INSULATION

NTS

WINTER PARK WATER AND SANITATION DISTRICT	
WATER PIPE INSTALLATION	
DATE: 7/31/2015	W-8

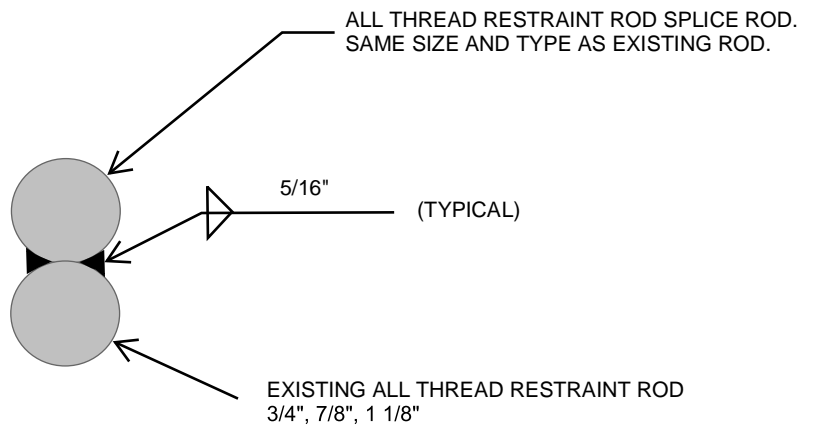
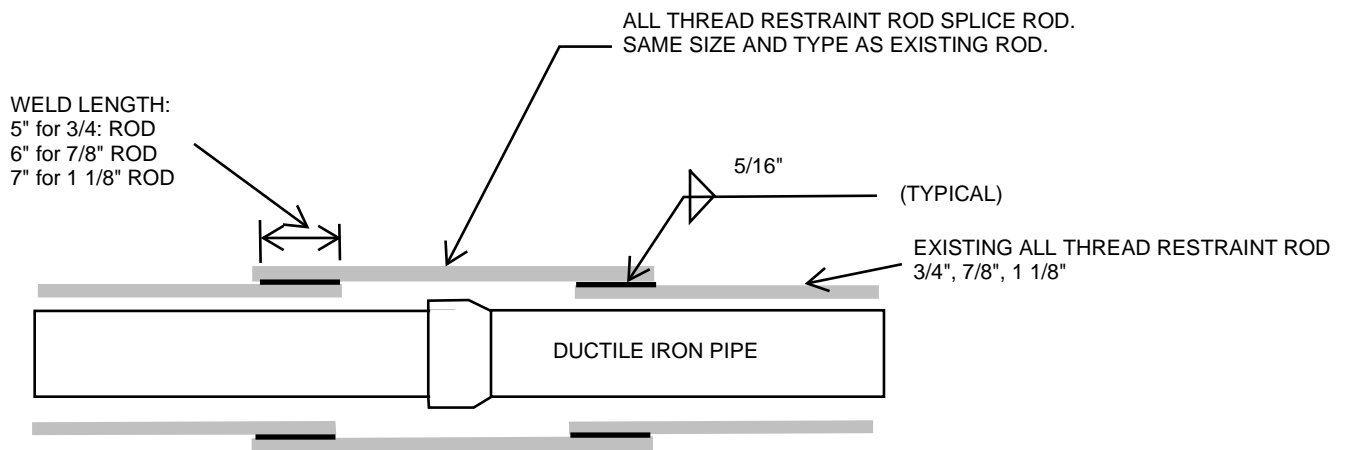
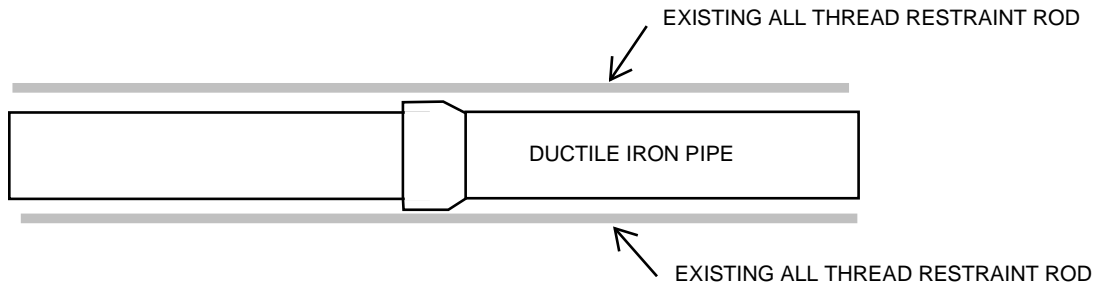

RESTRAINT ROD SPLICE

NOTES:
FOLLOWING INSTALLATION, ALL RESTRAINT RODS SHALL BE BITUMINOUS
COATED AND POLYWRAPPED

WINTER PARK WATER AND
SANITATION DISTRICT

RESTRAINT ROD SPLICE

DATE: 7/5/23

W-9

5/7/2015 11:14:15 AM, I:\PROJECTS\6844633_WP_SD_NEW_GENERAL_SEF_SUB_00\9_0_CAD\STANDARDDETAILS\2009 REVISIONS\DETAIL I-1.DWG-CHAVEZ, JULIAN

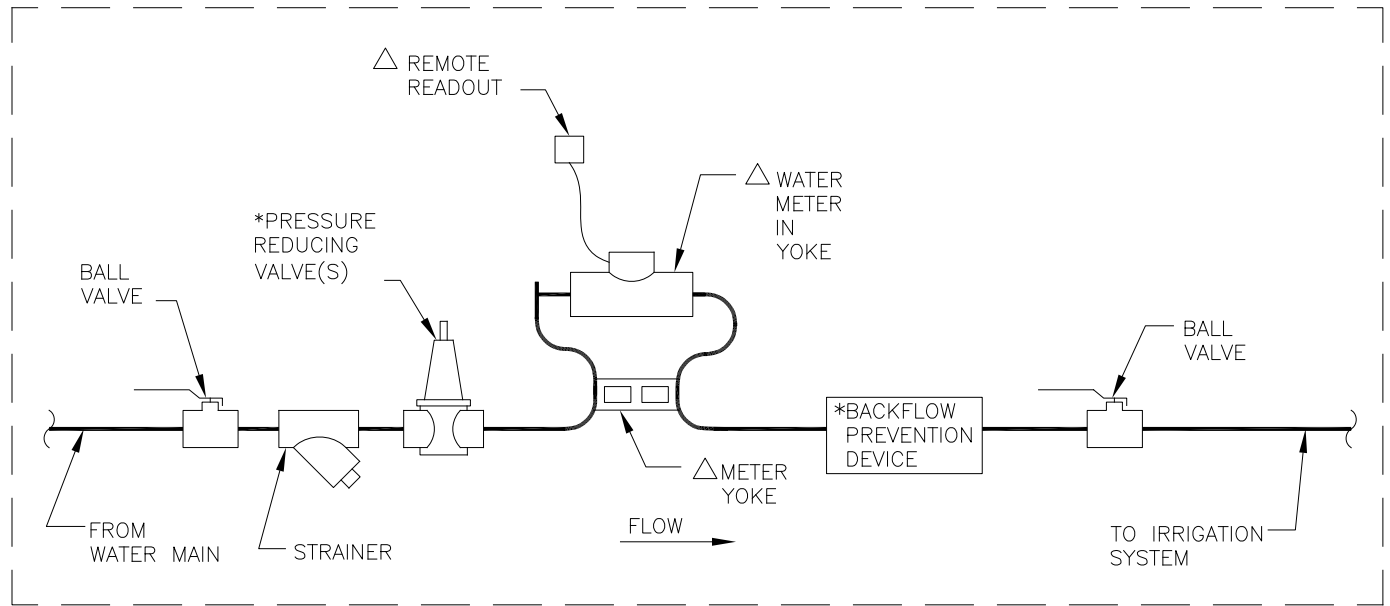

* EQUIPMENT FURNISHED BY DISTRICT;
OWNED AND MAINTAINED BY COMMON ENTITY.

△ EQUIPMENT FURNISHED, OWNED AND
MAINTAINED BY DISTRICT.

NOTES

1. A SEPARATE METER IS REQUIRED FOR IRRIGATION OF A COMMON AREA.
2. VALVES SHALL BE FULL-PORT VALVES.
3. LOCATION OF WATER METER SERVICE EQUIPMENT AND REMOTE READOUT SHALL BE APPROVED BY THE DISTRICT PRIOR TO CONSTRUCTION.
4. WATER SERVICE EQUIPMENT SHALL BE LOCATED IN A HEATED SPACE, WITH REASONABLE SPACE FOR SERVICE OF EQUIPMENT.
5. METER SHALL BE SET IN METER YOKE. CONTRACTOR SHALL COORDINATE WITH DISTRICT SO DISTRICT CAN FURNISH THE PROPER METER YOKE FOR THE INSTALLATION.
6. METER MUST BE MOUNTED WITH REGISTER UPRIGHT AND METER HORIZONTAL, AND IN ACCORDANCE WITH MANUFACTURERS INSTRUCTIONS.
7. LOCATION OF REMOTE READOUT SHALL BE VISIBLE FROM THE STREET AND SHALL BE ACCESSIBLE YEAR-ROUND. REMOTE READOUT SHALL NOT BE LOCATED UNDER EAVE WHERE SNOW OR ICE CAN INTERFERE WITH EQUIPMENT OPERATION OR WOULD LIMIT ACCESS.
8. BACKFLOW PREVENTION DEVICE MUST BE INSTALLED IN ACCORDANCE WITH MANUFACTURERS RECOMMENDATIONS.
9. TYPE OF BACKFLOW PREVENTION DEVICE WILL BE DETERMINED BY THE DISTRICT BASED ON THE THE BACKFLOW PREVENTION NEED. IF A REDUCED PRESSURE PRINCIPAL TYPE DEVICE IS REQUIRED, IT MUST BE LOCATED WHERE THE DEVICE CAN BE PLUMBED TO A DRAIN.
10. SOME HIGHER PRESSURE INSTALLATIONS MAY REQUIRE TWO PRESSURE REDUCING VALVES IN SERIES.
11. IF WATER SERVICE LOCATION IS IN CRAWL SPACE, EQUIPMENT SHALL BE LOCATED WITHIN 3 FEET OF THE CRAWL SPACE ENTRANCE.
12. BACKFLOW PREVENTION DEVICES MUST BE INSPECTED AND TESTED BY CERTIFIED SERVICE PERSONNEL ANNUALLY.
13. IRRIGATION OF COMMON AREAS WITH RESIDENTIAL METER IS NOT PERMITTED.

WINTER PARK WATER AND SANITATION DISTRICT	
COMMON AREA IRRIGATION METER	
DATE: 5/6/2015	I-1

2/24/2009 1:09:57 PM:T:\PROJECTS\6844633_WP_SD_NEW_GENERAL_SE\SUB_00\9.0_CAD\STANDARDDETAILS\2009 REVISIONS\DETAILS-1.DWG_JIM_HEALY

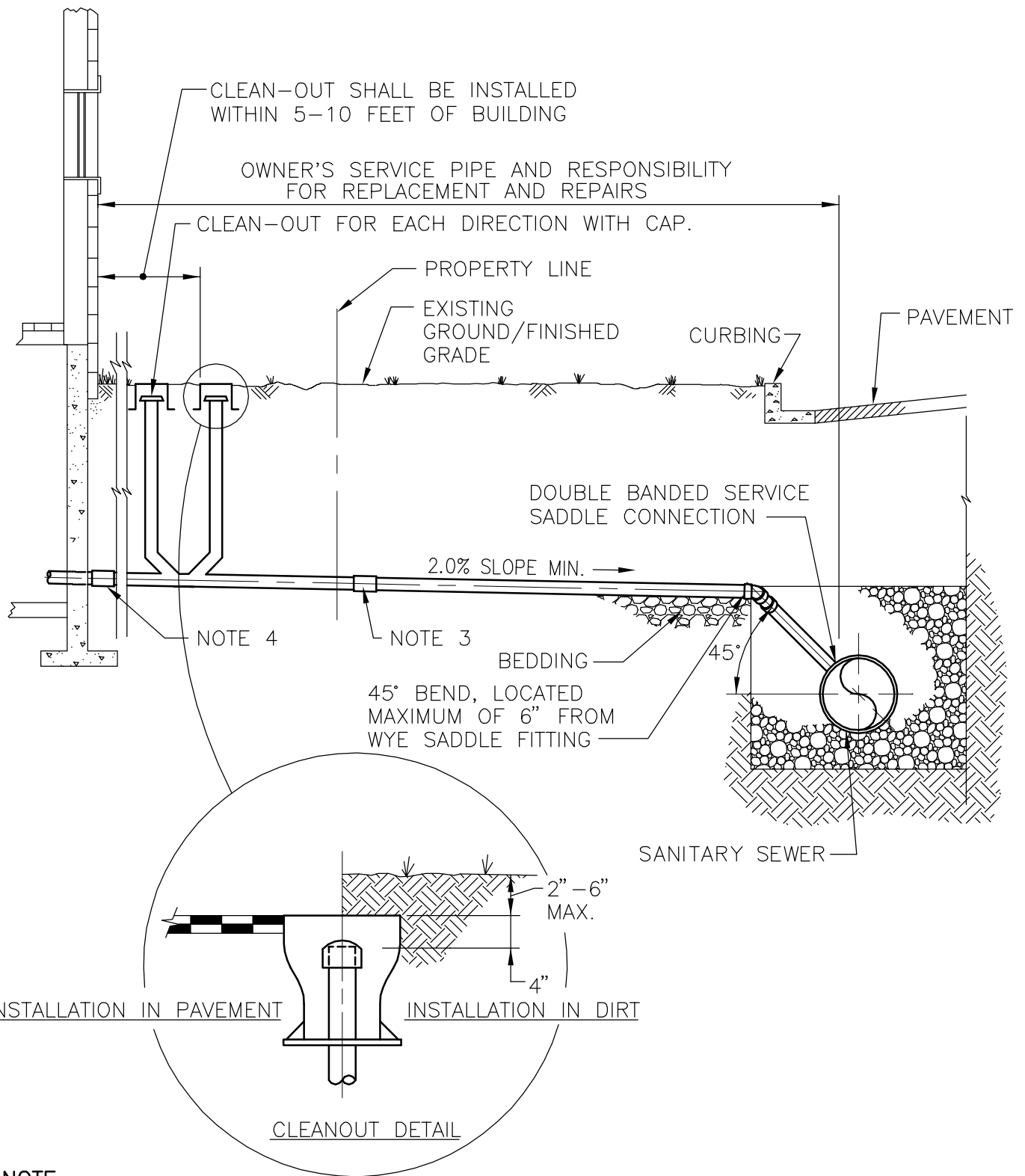

NOTE

1. HOLE IN SEWER SHALL ONLY BE CUT WITH HOLE SAW. COUPON SHALL BE PROVIDED TO DISTRICT INSPECTOR.
2. CLEANOUT BOX SHALL BE CAST IRON AND COVER STAMPED "CLEANOUT". CLEANOUT BOX SHALL BE INSTALLED STRAIGHT AND VERTICAL.
3. SOLID STAINLESS STEEL SLEEVE TYPE FLEXIBLE COUPLING SHALL BE USED IN THIS LOCATION, FERNCO PROFLEX OR EQUAL. NO PLAIN FLEXIBLE FERNCO TYPE RUBBER COUPLINGS ARE PERMITTED.
4. RIGID, GASKETED, COUPLING SHALL BE USED IN THIS LOCATION, NO RUBBER OR FLEXIBLE COUPLINGS PERMITTED.
5. GLUED CONNECTION ARE NOT PERMITTED.

WINTER PARK WATER AND SANITATION DISTRICT	
SINGLE FAMILY RESIDENCE SEWER SERVICE CONNECTION DETAIL	
DATE: 2/23/2009	S-1

2/24/2009 1:11:19 PM, T:\PROJECTS\6844633_WP_SD_NEW_GENERAL_SE\SUB_00\9.0_CAD\STANDARDDETAILS\2009 REVISIONS\DETAILS-2.DWG, JIM_HEALY

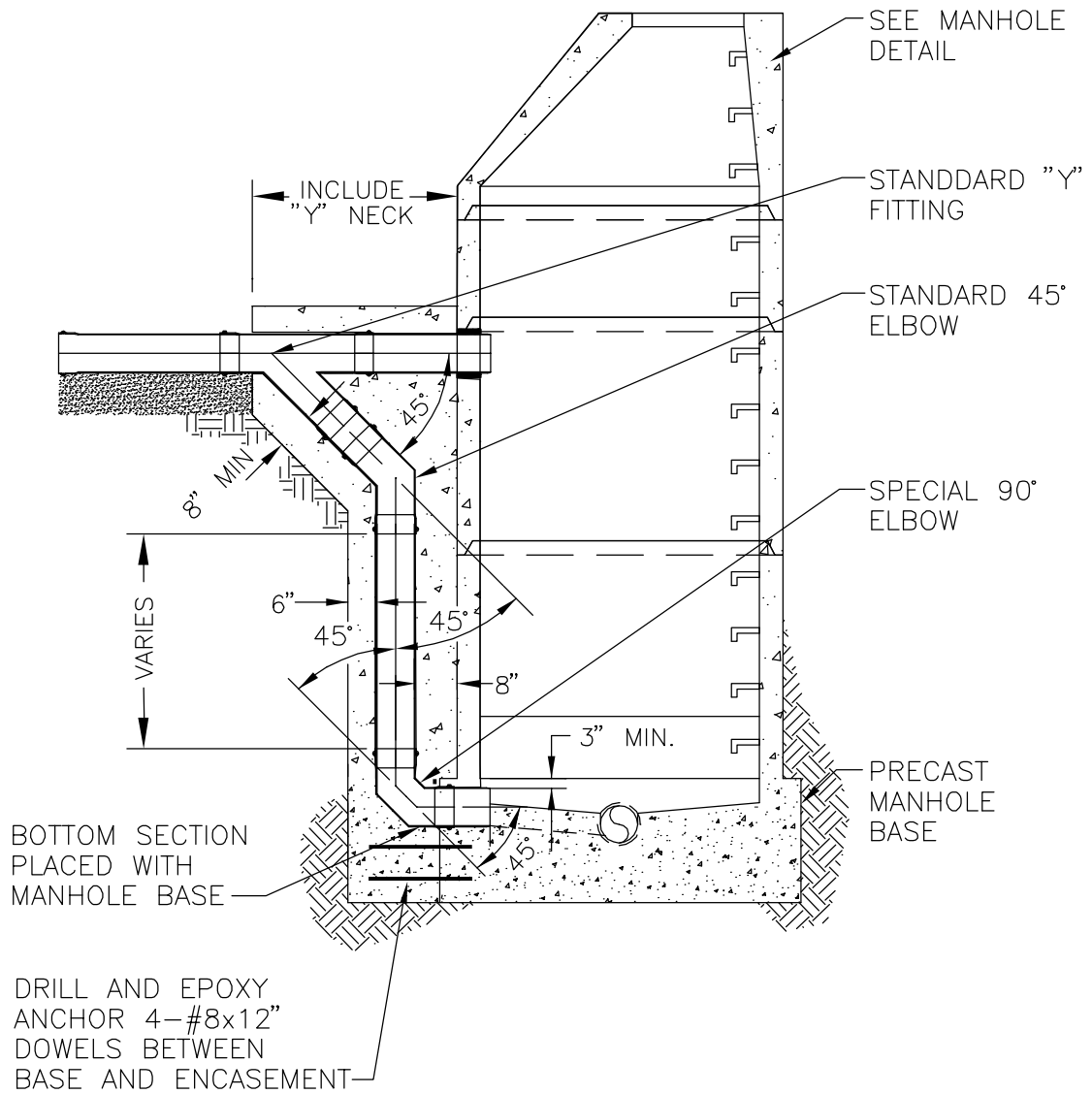

NOTES

1. CONCRETE ENCASEMENT SHALL BE CLASS II TYPE III MIN. 6" THICK ALL AROUND DROP.
2. DIAMETER OF DROP SHALL MATCH LINE PIPE DIAMETER.

WINTER PARK WATER AND
SANITATION DISTRICT

OUTSIDE DROP MANHOLE

DATE: 2/23/2009

S-2

3/24/2009 1:10:47 PM, T:\PROJECTS\6844633_WP_SD_NEW_GENERAL_SE\SUB_00\9.0_CAD\STANDARDDETAILS\2009 REVISIONS\DETAILS-3.DWG, JIM_HEALY

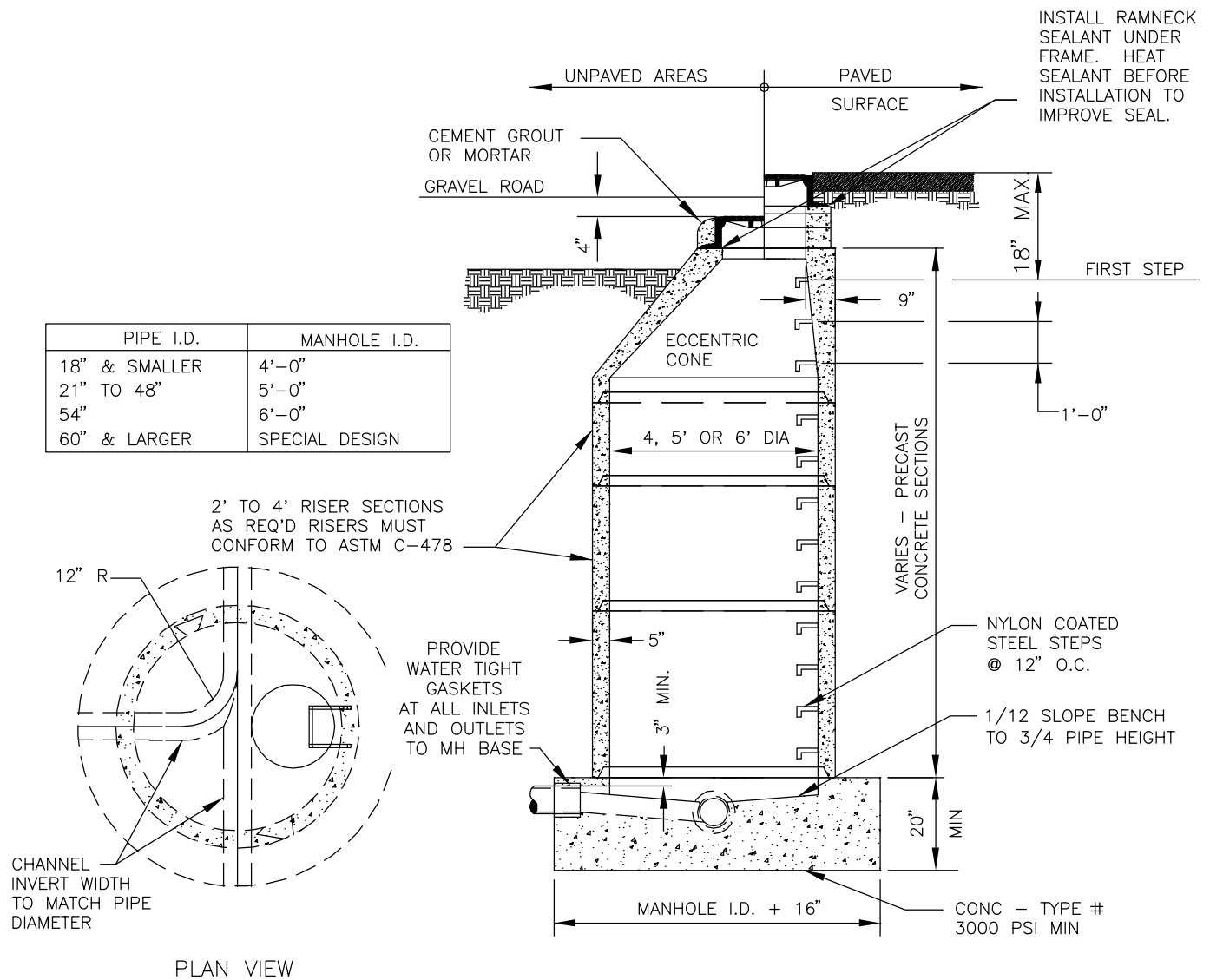

NOTES

1. BARREL DIAMETER SHALL CONFORM TO THE TABLE ABOVE.
2. FLAT CONCRETE MANHOLE TOPS MAY BE USED INSTEAD OF CONE SECTIONS WHERE RIM TO INVERT IS 7'-0" OR LESS.
3. SET EACH ADJUSTING RING IN A FULL BED OF BITUMINOUS MASTIC (RAMNECK).
4. MANHOLE STEPS SHALL BE POSITIONED OVER THE BENCH IN A VERTICAL LINE.
5. 12-INCH BITUMINOUS SHEETING (CONWRAP OR EQUAL) SHALL BE INSTALLED ON EXTERIOR OF ALL MANHOLE JOINTS, OVER BITUMINOUS TACK COAT.
6. MANHOLE LID SHALL BE 1/2" BELOW ASPHALT. FRAME AND LID SHALL BE SLOPED TO MATCH PAVEMENT USING THE WHIRLYGIG MANHOLE RISER-COLLAR CAST-IN-PLACE SYSTEM, OR EQUAL. (MANHOLE LIDS NOT CONFORMING TO THIS REQUIREMENT SHALL BE RESET AS NECESSARY.) WITH ROAD OVERLAY PROJECTS, MANHOLE RIM ADJUSTMENT RINGS MAY BE USED TO ADJUST MH RIM TO 1/2" BELOW THE REVISED ROADWAY GRADE.

WINTER PARK WATER AND SANITATION DISTRICT	
SEWER MANHOLE	
DATE: 3/24/2009	S-3

2/24/2009 1:13:51 PM, T:\PROJECTS\6844633_WP_SD_NEW_GENERAL_SE\SUB_00\9_0_CAD\STANDARDDETAILS\2009 REVISIONS\DETAILS-4.DWG, JIM_HEALY

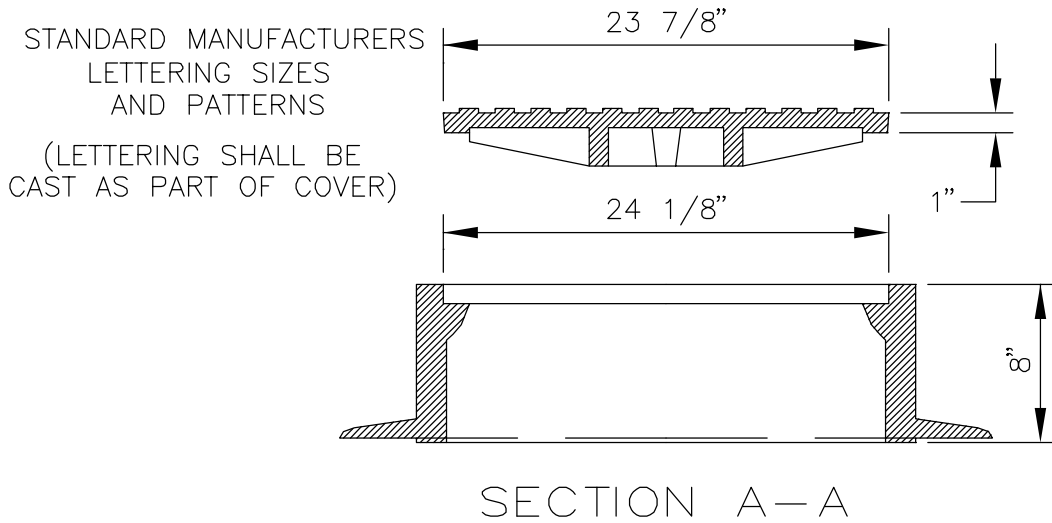
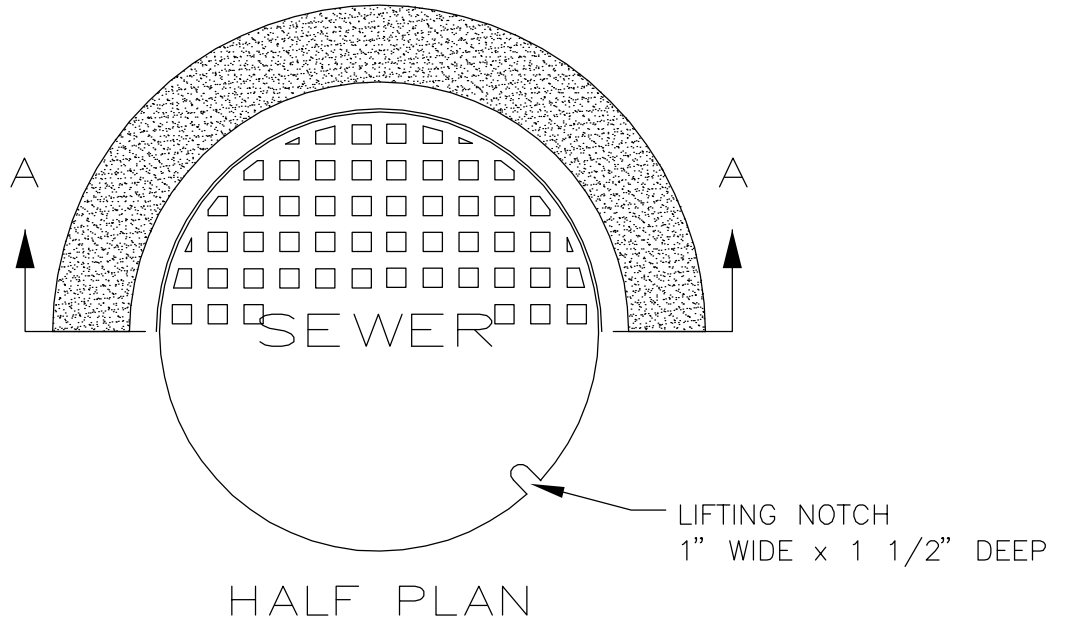

NOTES

1. CASTING SPECIFICATIONS: ASTM A-48 WITH A MINIMUM TENSILE STRENGTH OF 30,000 PSI (CLASS 30). (NEENAH TYPE R-1706 RING & COVER OR EQUIVALENT).
2. TOTAL MINIMUM WEIGHT APPROXIMATELY 410 LBS.
3. DO NOT USE IN APPLICATIONS WHERE MANHOLES ARE SUBJECTED TO DRAINAGE WAYS.

WINTER PARK WATER AND SANITATION DISTRICT	
24" MANHOLE RING AND COVER	
DATE: 2/23/2009	S-4

3/24/2009 1:12:26 PM, T:\PROJECTS\6844633_WP_SD_NEW_GENERAL_SE\SUB_00\9.0_CAD\STANDARDDETAILS\2009 REVISIONS\DETAILS-5.DWG, JIM_HEALY

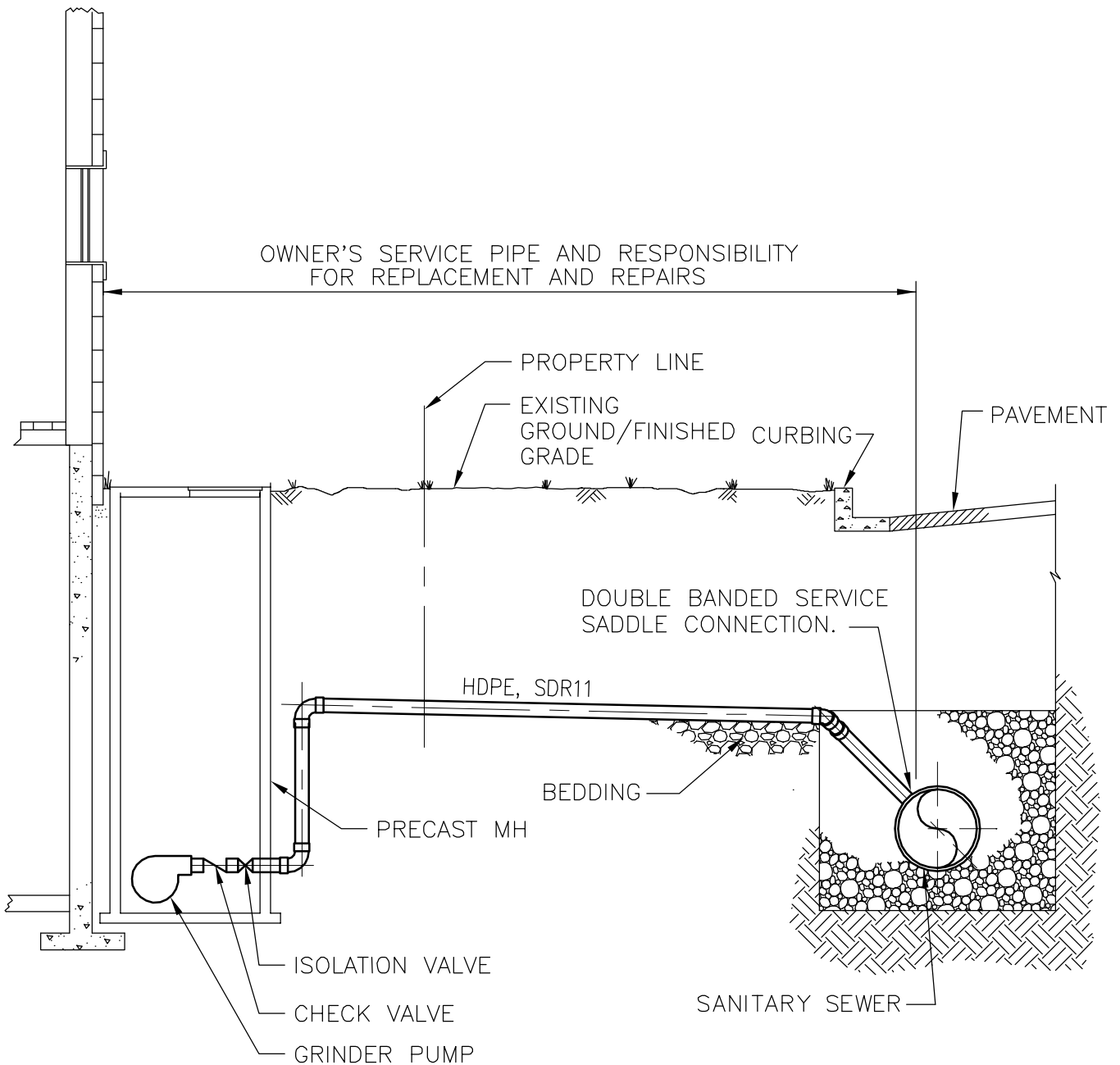

NOTE

1. HOLE IN SEWER SHALL ONLY BE CUT WITH HOLE SAW. COUPON SHALL BE PROVIDED TO DISTRICT.
2. ALL FITTINGS SHALL BE RATED FOR 150 PSI SERVICE.
3. FORCE MAINS LESS THAN 4 INCHES IN DIAMETER MUST CONNECT TO THE PUBLIC SANITARY SEWER THROUGH A STANDARD WYE. THE FORCE MAIN MUST CONNECT TO THE TEE OR WYE IN A MANNER TO PREVENT SEWAGE FROM ENTERING THE FORCE MAIN WHEN THE MAIN LINE SEWER IS FLOWING FULL. AFTER THE CONNECTIONS ARE INSPECTED THE CONNECTION MUST CONCRETE ENCASED TO PREVENT SEPARATION DUE TO THRUST.
4. GLUED CONNECTIONS ARE NOT PERMITTED.

WINTER PARK WATER AND SANITATION DISTRICT	
GRINDER PUMP SERVICE CONNECTION	
DATE: 3/24/2009	S-5

8/6/2009 11:17:44 AM, T:\PROJECTS\6844633_WP_SD_NEW_GENERAL_SE\SUB_00\9.0_CAD\STANDARDDETAILS\2009 REVISIONS\DETAILS-6.DWG,RAU, MICHAEL

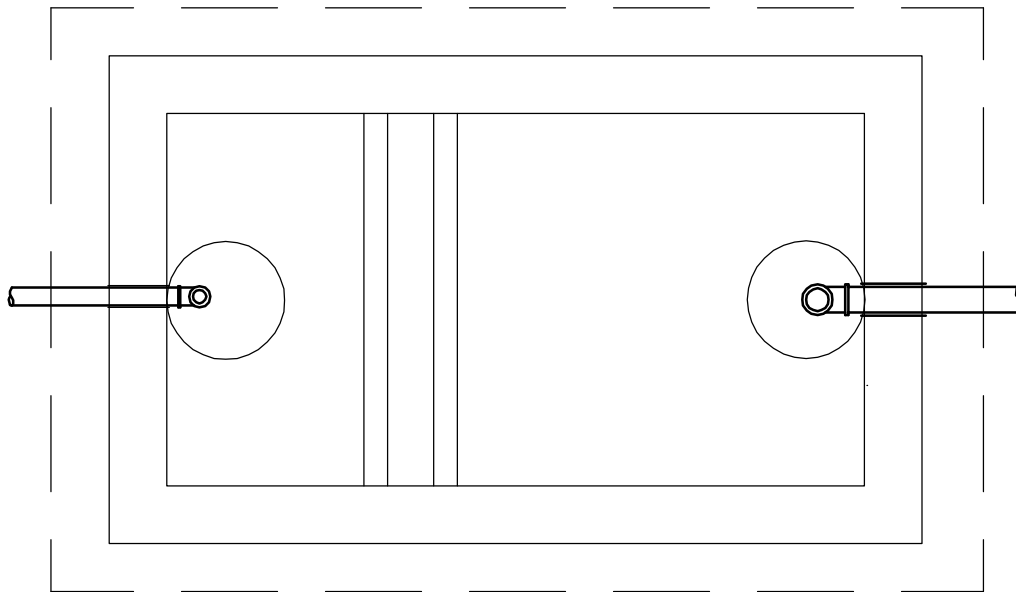
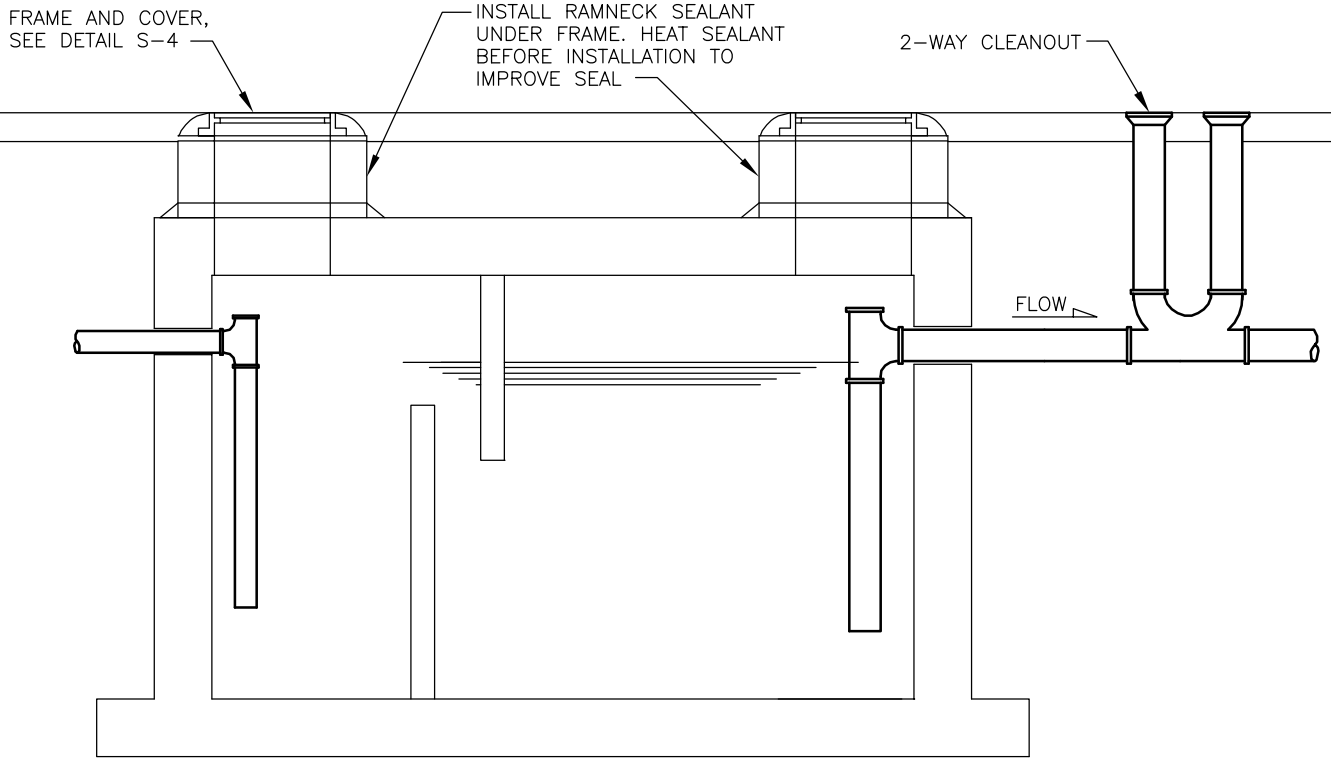

NOTES

1. BACKFILL SHALL BE COMPACTED IN MAXIMUM 6" LIFTS. IF RISERS ARE NOT PLUMB, CONTRACTOR SHALL RESET.
2. SET EACH ADJUSTING RING IN A FULL BED OF BITUMINOUS MASTIC (RAMNECK SEALANT).
3. 12" BITUMINOUS SHEETING (CONWRAP OR EQUAL) SHALL BE INSTALLED ON ALL MANHOLE JOINTS OVER BITUMINOUS TACK COAT.

WINTER PARK WATER AND
SANITATION DISTRICT

GREASE INTERCEPTOR

DATE: 7/22/2009

S-6